



Warning



- Ask a qualified installer or contractor to install this product. Do not try to install the product yourself. Improper installation can result in water or refrigerant leakage, electrical shock, fire or explosion.
 - Use only those parts and accessories supplied or specified by Daikin. Ask a qualified installer or contractor to install those parts and accessories. Use of unauthorised parts and accessories or improper installation of parts and accessories can result in water or refrigerant leakage, electrical shock, fire or explosion.
 - Read the user's manual carefully before using this product. The user's manual provides important safety instructions and warnings. Be sure to follow these instructions and warnings.
- If you have any enquiries, please contact your local importer, distributor and/or retailer.

Cautions on product corrosion

1. Air conditioners should not be installed in areas where corrosive gases, such as acid gas or alkaline gas, are produced.
2. If the outdoor unit is to be installed close to the sea shore, direct exposure to the sea breeze should be avoided. If you need to install the outdoor unit close to the sea shore, contact your local distributor.



PCVHK1540

VRV IV S SERIES



For residential and commercial use

R-410A

Heat Pump 50 Hz

Engineered for Flexibility

First launched in Japan in 1982, the Daikin VRV system has been embraced by world markets for over 30 years. Now, Daikin proudly introduces the new VRV IV S series—the ideal air conditioning system for homes, shops and offices.

VRV IV S SERIES

VRV indoor units combine with residential indoor units, all in one system.



* VRV is a trademark of Daikin Industries, Ltd.

Contents

- Main Features P03
- Indoor Unit Lineup P09
- Specifications P31
- Option List P43
- Control Systems P49
- Air Treatment Equipment Lineup P61

OFFICES



SHOPS



HOMES



Main Features

Compact & lightweight design

The new design has been optimised for the VRV IV S series, with the height of 3 HP to 5 HP models reduced to only 990 mm. This design gives the building a sleek look externally and provides the occupants with a clear, unobstructed view of the scenery. The VRV IV S series is now slim and compact, with outdoor units that require minimal installation space.

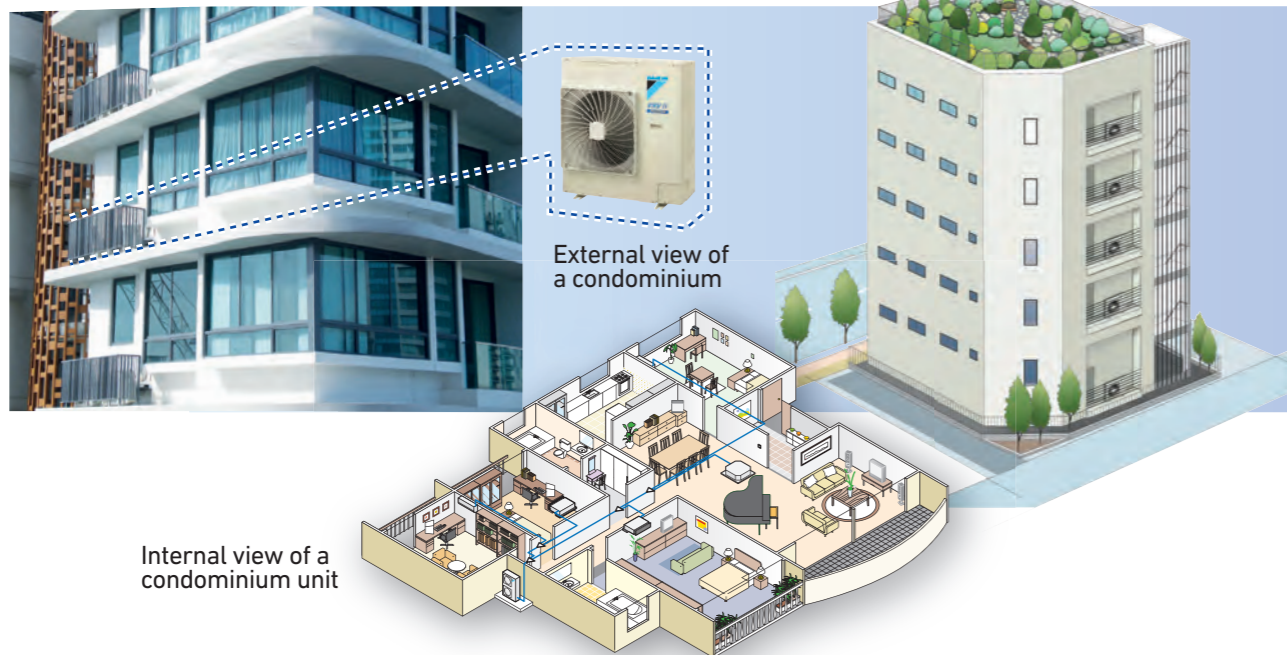

Enhanced lineup

To suit a variety of room sizes, VRV IV S series expands our range to include 3 HP, 8 HP and 9 HP.

VRV IV S SERIES

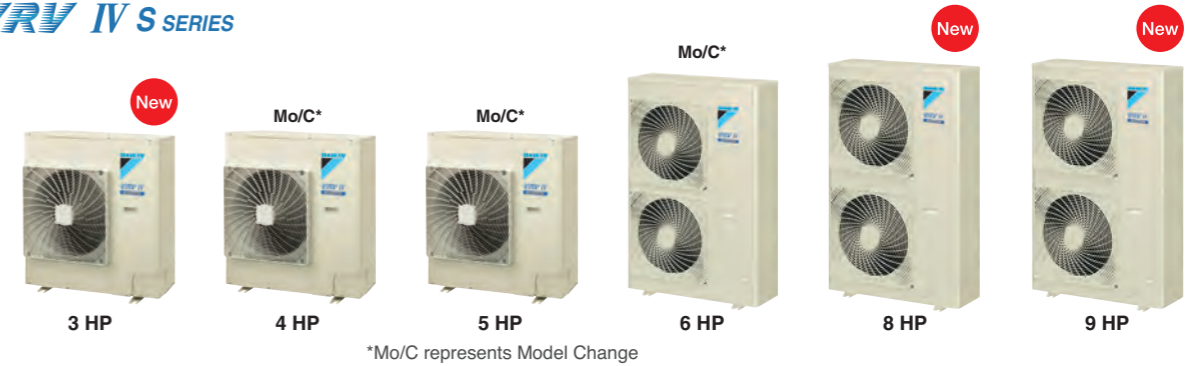

Lineup

Model Name	RXYMQ3AVE	RXYMQ4AVE	RXYMQ5AVE	RXYMQ6AVE	RXYMQ8AY1	RXYMQ9AY1
Power Supply	1-phase, 220-230 V/220 V, 50/60 Hz				3-phase, 380-415 V, 50 Hz	
Capacity Range	3 HP (9.0 kW)	4 HP (11.2 kW)	5 HP (14.0 kW)	6 HP (16.0 kW)	8 HP (22.4 kW)	9 HP (24.0 kW)
Capacity Index	80	100	125	150	200	215

6 models

Wide variety of indoor units

Indoor units can be selected from 2 lineups, both VRV and residential indoor units, to match rooms and preferences. A mixed combination of VRV indoor units and residential indoor units can be included into one system, opening the door to stylish and quiet indoor units.



Main Features

Energy saving

Higher Coefficient of Performance (COP)

VRV IV S series provides greater energy saving as compared to VRV III S series, especially for 6 HP.

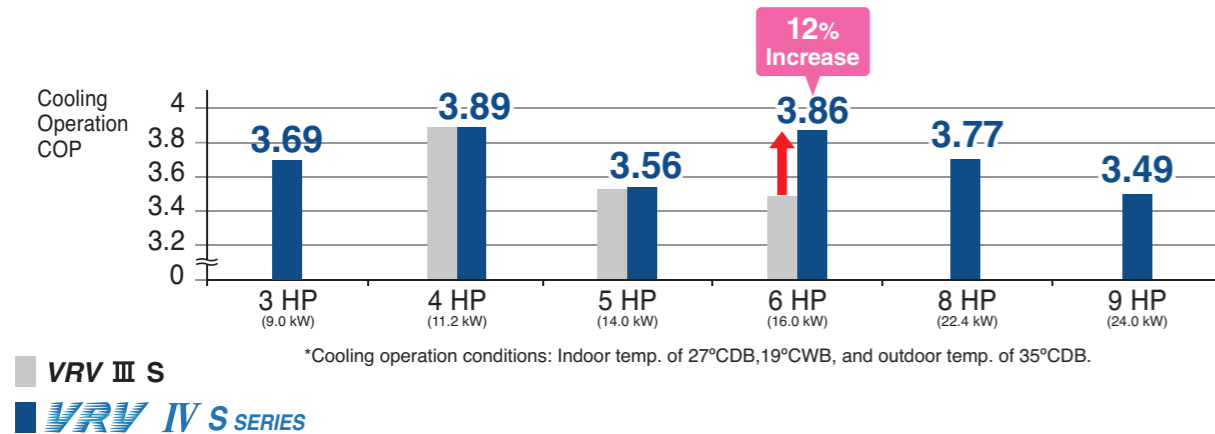

Collection of cutting-edge technologies realises efficient and quiet operation

The high efficiency compressor to achieve a higher COP

1 Compressor equipped with Reluctance DC motor

Daikin DC inverter models are equipped with the Reluctance DC motor for compressor. The Reluctance DC motor uses 2 different types of torque, neodymium magnet*1 and reluctance torque*2. This motor can save energy because it generates more power with a smaller electric power than an AC or conventional DC motor.

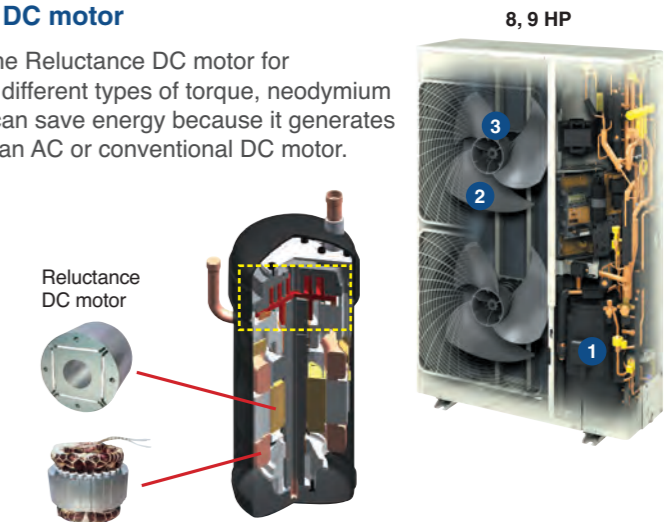
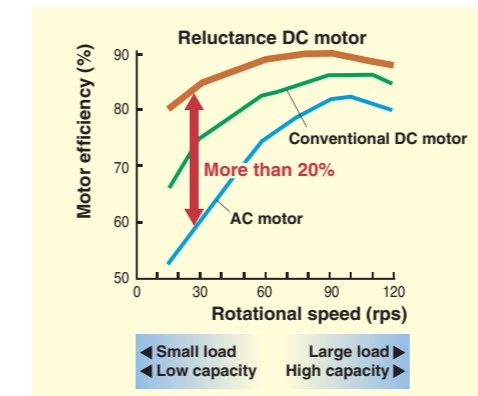

Note: Data are based on studies conducted under controlled conditions at a Daikin laboratory using Daikin products.

*1 A neodymium magnet is approximately 10 times stronger than a standard ferrite magnet.

*2 The torque created by the change in power between the iron and magnet parts.

>> Smooth sine wave DC inverter

Use of an optimised sine wave smoothes motor rotation, further improving operating efficiency.

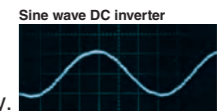

Quiet operation

Nighttime quiet operation function

Operation sound level selectable from 3 steps for the night mode

Mode 1. Automatic mode

Set on the outdoor PCB. Time of maximum temperature is memorised. The low operating mode will initiate 8 hours*1 after the peak temperature in the daytime, and normal operation will resume 10 hours*2 after that. The operation sound level for the night mode can be selected from 49 dB(A) (Step 1), 46 dB(A) (Step 2) and 43 dB(A) (Step 3).*3

Mode 2. Manual mode

Starting time and ending time can be input. (An external control adaptor for outdoor unit, DTA104A53/61/62, and a locally obtained timer are necessary.)

Mode 3. Combined mode

Combinations of modes 1 and 2 can be used depending on your needs.

*1. Initial setting. Can be selected from 6, 8 and 10 hours.
*2. Initial setting. Can be selected from 8, 9 and 10 hours.
*3. In case of 4 HP outdoor unit during cooling operation

Mode 1. Automatic mode

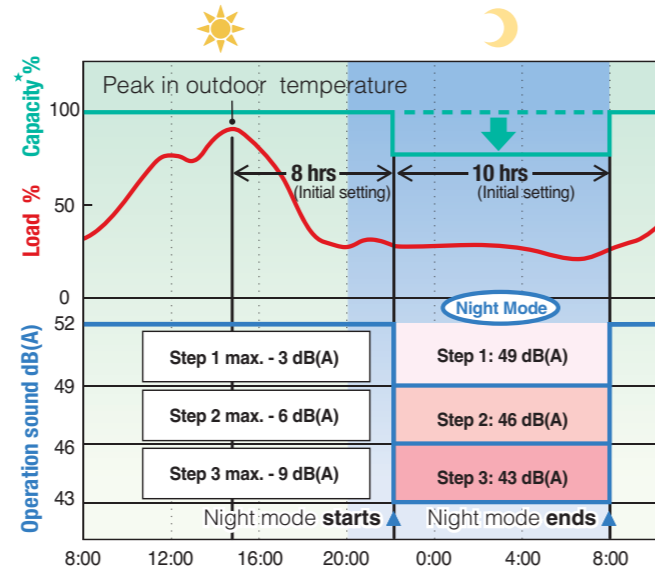

Note: • This function is available in setting at site.
• The relationship of outdoor temperature (load) and time shown in the graph is just an example.
* The capacity reduction rate differs depending on the operation sound level step selected.

RXYMQ 3, 4, 5, 6AVE

>> Swing compressor

Daikin swing compressor has integrated the rotor with the blade, completely solving the refrigerant leakage and the wear problem caused by the mechanical friction between the rotor and the blade, which enhances the compressor efficiency and makes the compressor more quiet and durable.

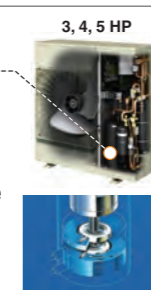

RXYMQ8, 9AY1

>> Scroll compressor

Sucked gas is compressed in the scrolling part before the heated motor, so that the machine compresses the non-expanded gas, resulting in high efficiency compression.

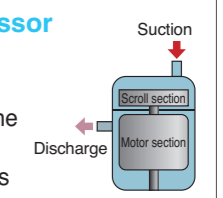

2 Smooth Air Inlet Bell Mouth and Aero Spiral Fan

These two features work to reduce sound. Guides are added to the bell mouth intake to reduce turbulence in the airflow generated by fan suction. The Aero Spiral Fan features fan blades with the bent blade edges, further reducing turbulence.

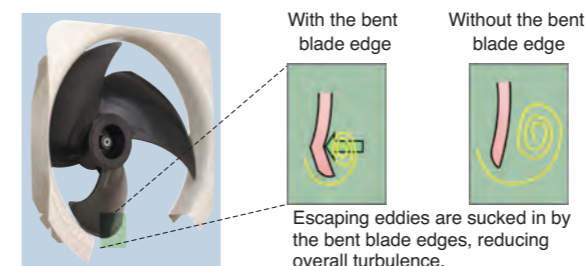

3 DC fan motor

Efficiency improved in all areas compared to conventional AC motors, especially at low speeds.

DC fan motor structure



Main Features

Design flexibility and simplified installation

Connectable up to 14 indoor units

As many as 14 indoor units can be connected to a single outdoor unit, making the VRV IV S series a remarkably versatile system.

Note: Refer to page 42 for the maximum number of connectable indoor unit and outdoor unit combination details.

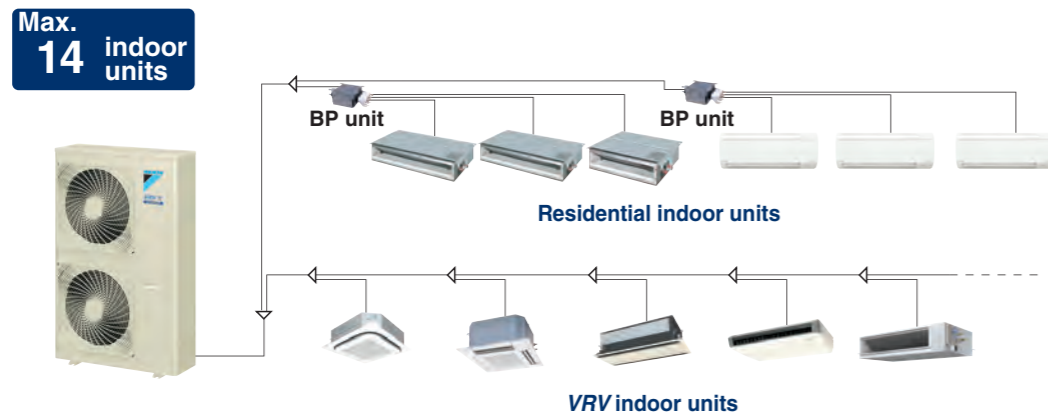

Automatic test operation

Simply press the test operation button and the unit performs an automatic system check, including wiring, stop valves, piping, and refrigerant charging amount. The results are returned automatically after the check finishes.

Simple wiring and piping connection

Unique piping and wiring systems make it possible to install a VRV IV S series quickly and easily.

>> Super wiring system

A super wiring system is used to enable shared use of the wiring between indoor and outdoor units and the central control wiring, with a relatively simple wiring operation.

The DIII-NET communication system is employed to enable the use of advanced control systems.

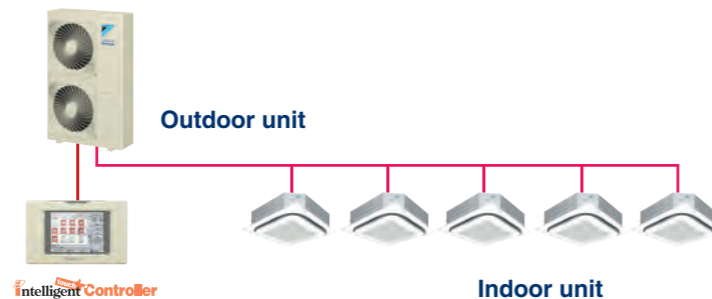

>> REFNET piping system

Daikin's advanced REFNET piping system makes installation easy. Only two main refrigerant lines are required in any one system. REFNET greatly reduces the imbalances in refrigerant flow between units, while using small-diameter piping.

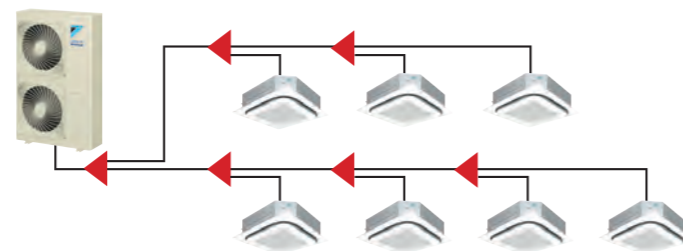

Long piping design possible

Long piping length offers flexibility in the choice of installation positions, and simplifies system planning.

When only VRV indoor units are connected

Actual piping length
Max. 120 m

Total piping length
Max. 300 m

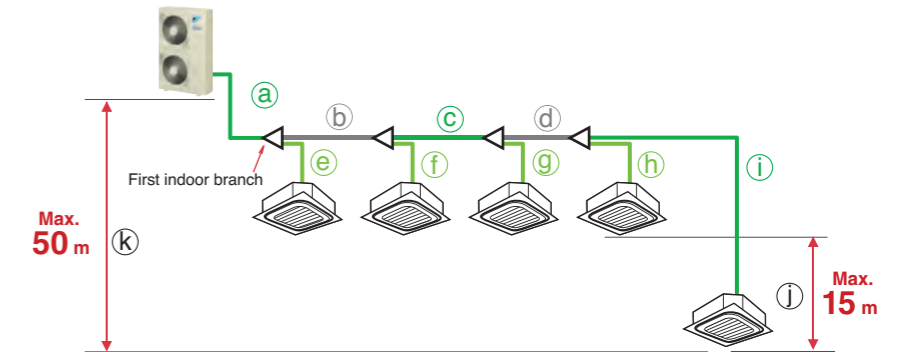

			3, 4 HP	5 HP	6 HP	8,9 HP
Max. allowable piping length	Refrigerant piping length	a+b+c+d+i	50 m	70 m	120 m	100 m
	Total piping length	a+b+c+d+e+f+g+h+i	250 m	300 m	300 m	300 m
	Between the first indoor branch and the farthest indoor unit	b+c+d+i	40 m	40 m	40 m	40 m
Max. allowable level difference	Between the indoor units	j	10 m	15 m	15 m	15 m
	Between the outdoor unit and the indoor unit	If the outdoor unit is above	k	30 m	30 m	50 m
	If the outdoor unit is below	k	30 m	30 m	40 m	40 m

When a mixed combination of VRV and residential indoor units is connected or when only residential indoor units are connected

Actual piping length
Max. 100 m

Total piping length
Max. 250 m

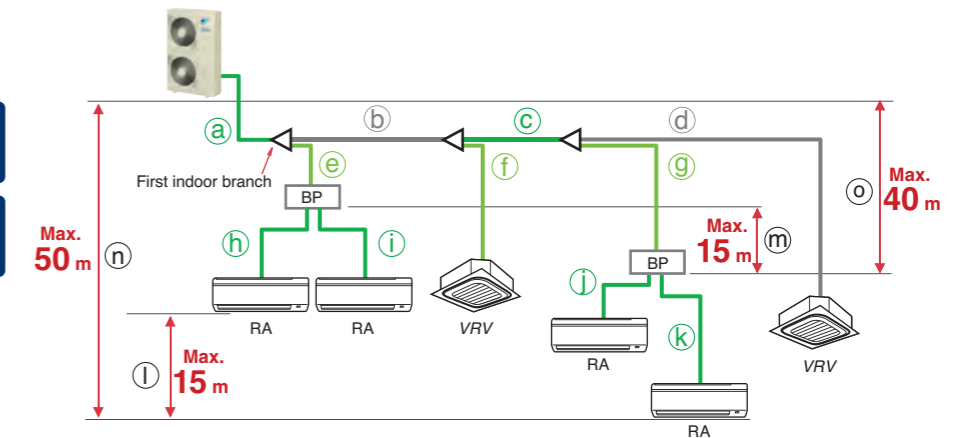

			3, 4 HP	5 HP	6-9 HP	
Max. allowable piping length	Refrigerant piping length	a+b+c+g+k, a+b+c+d	50 m	70 m	100 m	
	Total piping length	a+b+c+d+e+f+g+h+i+j+k	250 m	250 m	250 m	
	The first indoor branch - the farthest BP or VRV indoor unit	b+c+g, b+c+d	40 m	40 m	40 m	
Max. & min. allowable piping length	BP unit - indoor unit	If indoor unit capacity index < 60	2 m-15 m	2 m-15 m	2 m-15 m	
		If indoor unit capacity index is 60	2 m-12 m	2 m-12 m	2 m-12 m	
		If indoor unit capacity index is 71	2 m-8 m	2 m-8 m	2 m-8 m	
Min. allowable piping length	Outdoor unit - the first indoor branch	a	5 m	5 m	5 m	
Max. allowable level difference	Between the indoor units	l	10 m	15 m	15 m	
	Between BP units	m	10 m	15 m	15 m	
	Outdoor unit - the indoor unit	If the outdoor unit is above	n	30 m	30 m	50 m
	If the outdoor unit is below	n	30 m	30 m	40 m	
	Outdoor unit - the BP unit	o	30 m	30 m	40 m	

Indoor Unit Lineup

Enhanced range of choices

A mixed combination of VRV indoor units and residential indoor units can be included into one system, opening the door to stylish and quiet indoor units.

VRV indoor units

17 types 90 models

Type	Model Name	Capacity Range	Capacity Index															
			0.8 HP	1 HP	1.25 HP	1.6 HP	2 HP	2.5 HP	3 HP	3.2 HP	4 HP	5 HP	6 HP	8 HP	10 HP			
Ceiling Mounted Cassette (Round Flow with Sensing)	FXFQ-SVM		●	●	●	●	●			●	●	●						
Ceiling Mounted Cassette (Round Flow)	FXFQ-LUV1			●	●	●	●			●	●	●						
Ceiling Mounted Cassette (Compact Multi Flow)	FXZQ-MVE		●	●	●	●	●											
4-Way Flow Ceiling Suspended	FXUQ-AVEB								●			●						
Ceiling Mounted Cassette (Double Flow)	FXCQ-MVE		●	●	●	●	●	●		●			●					
Ceiling Mounted Cassette Corner	FXKQ-MAVE			●	●	●		●										
Slim Ceiling Mounted Duct	FXDQ-PBVE (with drain pump)		●	●	●													
	FXDQ-PBVET (700 mm width type) (without drain pump)		●	●	●													
	FXDQ-NBVE (with drain pump)						●	●	●									
	FXDQ-NBVET (900/1,100 mm width type) (without drain pump)						●	●	●									
Middle Static Pressure Ceiling Mounted Duct	New FXSQ-PVE		New	New	New	New	New	New		New	New	New	New					
Ceiling Mounted Duct	FXMQ-PVE		●	●	●	●	●	●		●	●	●	●					
	FXMQ-MAVE													●	●			
Ceiling Suspended	FXHQ-MAVE				●			●			●							
Wall Mounted	FXAQ-PVE		●	●	●	●	●	●										
Floor Standing	FXLQ-MAVE		●	●	●	●	●	●										
Concealed Floor Standing	FXNQ-MAVE		●	●	●	●	●	●										

Residential indoor units with connection to BP units

4 types 12 models

Type	Model Name	Rated Capacity	20	25	35	50	60	71
			Capacity Index	2.0 kW	2.5 kW	3.5 kW	5.0 kW	6.0 kW
Slim Ceiling Mounted Duct	CDXS-EAVMA (700 mm width type)			●	●			
	FDXS-CVMA (900/1,100 mm width type)			●	●	●	●	
Wall Mounted	FTXS-DVMA		●					
	FTXS-EVMA			●	●			
	FTXS-FVMA					●	●	●

Note: BP units are necessary for residential indoor units.

VRV indoor units combine with indoor units, all in one system.

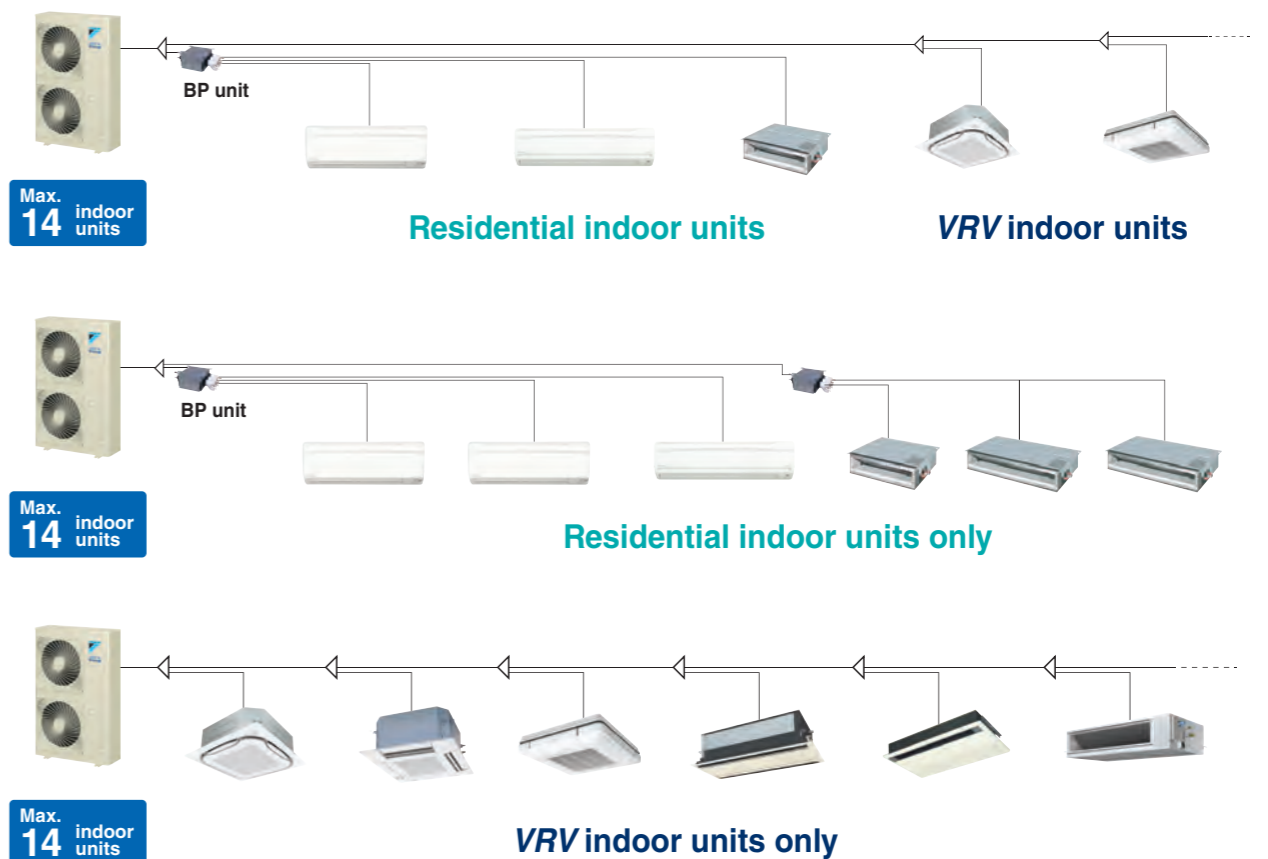

*Refer to page 42 for the maximum number of connectable indoor units.

Indoor Unit Lineup

Daikin offers a wide range of indoor units includes both VRF and residential models responding to variety of needs of our customers that require air-conditioning solutions.

VRF indoor units

Ceiling Mounted Cassette (Round Flow with Sensing) Type

FXFQ-SVM



Presence of people and floor temperature can be detected to provide comfort and energy savings



Ceiling Mounted Cassette (Round Flow) Type

FXFQ-LUV1



360° airflow improves temperature distribution and offers a comfortable living environment.



Ceiling Mounted Cassette (Compact Multi Flow) Type

FXZQ-MVE

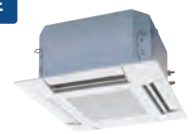

Quiet, compact, and designed for user comfort



4-Way Flow Ceiling Suspended Type

FXUQ-AVEB



This slim and stylish indoor unit achieves optimum air distribution, and can be installed without the need for ceiling cavity



Ceiling Mounted Cassette (Double Flow) Type

FXCQ-MVE

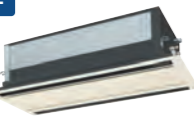

Thin, lightweight, and easy to install in narrow ceiling spaces



Ceiling Mounted Cassette Corner Type

FXKQ-MAVE

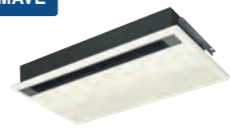

Slim design for flexible installation



Slim Ceiling Mounted Duct Type (Standard Series)

FXDQ-PBVE(T)

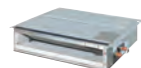

FXDQ-NBVE(T)

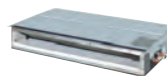

Slim design, quietness and static pressure switching



Middle Static Pressure Ceiling Mounted Duct Type

New FXSQ-PVE



Middle external static pressure and slim design allow flexible installations



Ceiling Mounted Duct Type

FXMQ-PVE



FXMQ-MAVE



High external static pressure allows flexible installations



Ceiling Suspended Type

FXHQ-MAVE



Slim body with quiet and wide airflow



Wall Mounted Type

FXAQ-PVE



Stylish flat panel design harmonised with your interior décor



Floor Standing Type

FXLQ-MAVE



Suitable for perimeter zone air conditioning



Concealed Floor Standing Type

FXNQ-MAVE

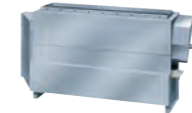

Designed to be concealed in the perimeter skirting-wall



Residential indoor units with connection to BP units

Slim Ceiling Mounted Duct Type

CDXS-EAVMA

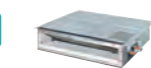

FDXS-CVMA



Slim and smooth design suits your shallow ceiling



Wall Mounted Type

FTXS-DVMA
FTXS-EVMA



FTXS-FVMA



Stylish flat panel harmonises with your interior décor



Indoor Unit Lineup

VRV Indoor Units

Ceiling Mounted Cassette (Round Flow with Sensing) Type

FXFQ25S / FXFQ32S / FXFQ40S
FXFQ50S / FXFQ63S / FXFQ80S
FXFQ100S / FXFQ125S



Presence of people and floor temperature can be detected to provide comfort and energy savings

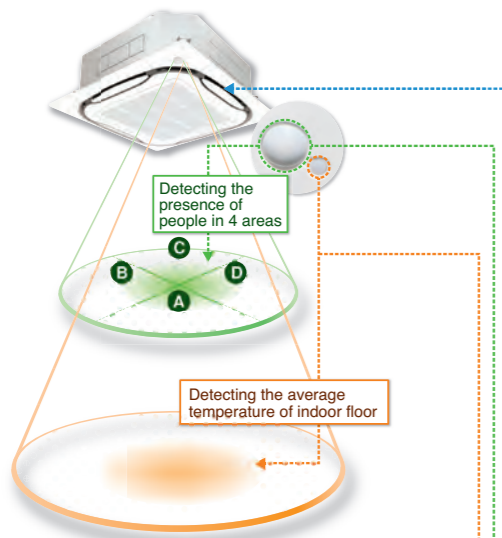

- Indoor unit offers 360° airflow discharges air in all directions with more uniform temperature distribution.

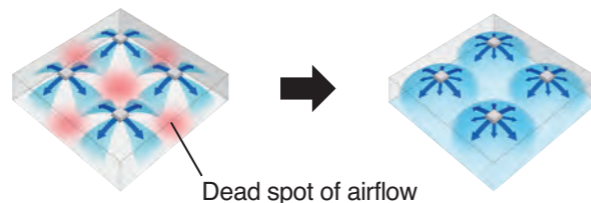

- Improved energy efficiency thanks to a new heat exchanger with smaller tubes, DC fan motor, and DC drain pump motor.

- Low operation sound level

FXFQ-S	25/32	40	50	63	80	100	125
Sound level (H/M/L)	30/28.5/27	31/29/27	36/32/28	38/33/28	38/35/31	44/38/32	45/40/35

- Drain pump is equipped as standard accessory with 850 mm lift.

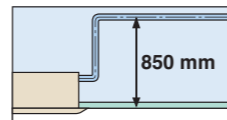

- Selectable airflow rate: 3 steps and Auto. (Auto airflow rate is available when BRC1E62 is used.)

Individual airflow direction control

Thanks to the individual airflow direction control function, airflow direction can be individually adjusted for each air discharge outlet to prevent uncomfortable drafts and to deliver optimal air distribution.

Infrared presence sensor

The sensor detects human presence and adjusts the airflow direction automatically to prevent drafts.

Ceiling height	2.7m	3.5m	4.0m
Detection range (diameter)*1	approx. 8.5m	approx. 11.5m	approx. 13.5m

*1. The infrared presence sensor detects 80 cm above the floor.

Infrared floor sensor

The sensor detects the floor temperature and automatically adjusts operation of the indoor unit to reduce the temperature difference between the ceiling and the floor.

Ceiling height	2.7m	3.5m	4.0m
Detection range (diameter)*2	approx. 11m	approx. 14m	approx. 16m

*2. The infrared floor sensor detects at the floor surface.

Sensing function

Draft prevention function (default: OFF) *1. 2

Auto airflow direction mode

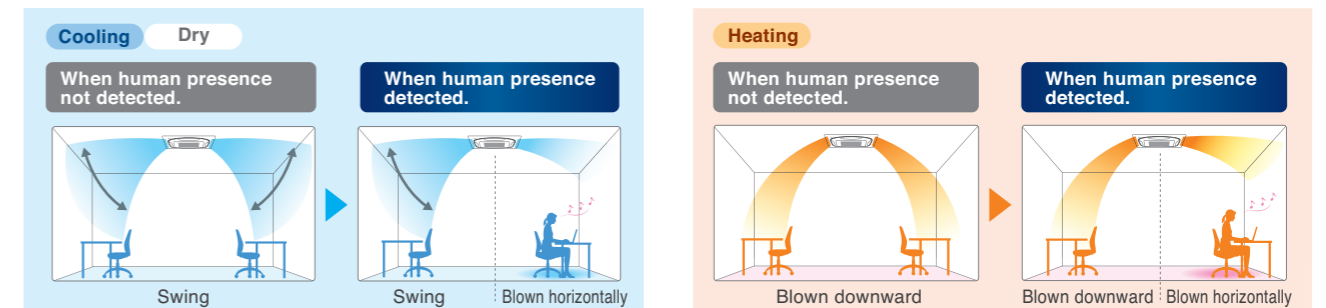

- With the Auto airflow direction mode, flaps are controlled to deliver optimal air distribution for both cooling and heating operations when there are no people.

- When a person is detected, drafts are prevented by making the flap horizontal.

- When a person is not detected for 5 minutes, the unit automatically returns to controlling the flaps for an unoccupied room. *1. Airflow direction should be set to Auto. *2. Draft prevention function is OFF in the initial setting. It can be set ON using the remote controller.

Comfort and Energy saving preventing over Cooling / Heating *1. 2

Auto airflow direction mode + Auto airflow rate mode

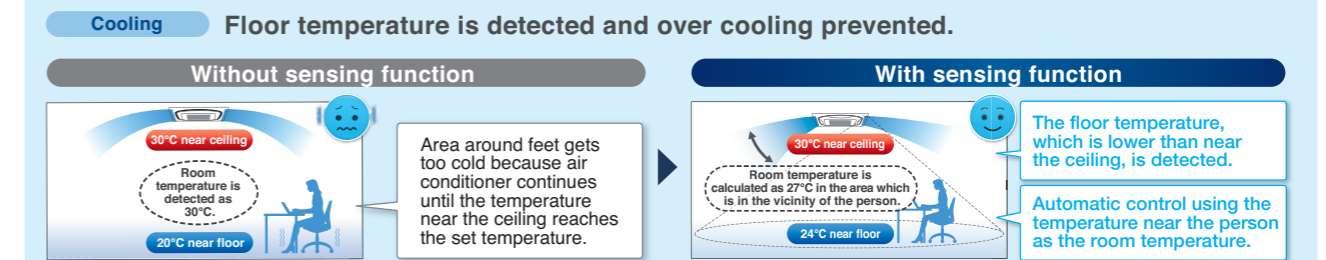

- The temperature near the person is automatically calculated by detecting the temperature of the floor. Energy is saved, because the area around the feet does not get too cold.

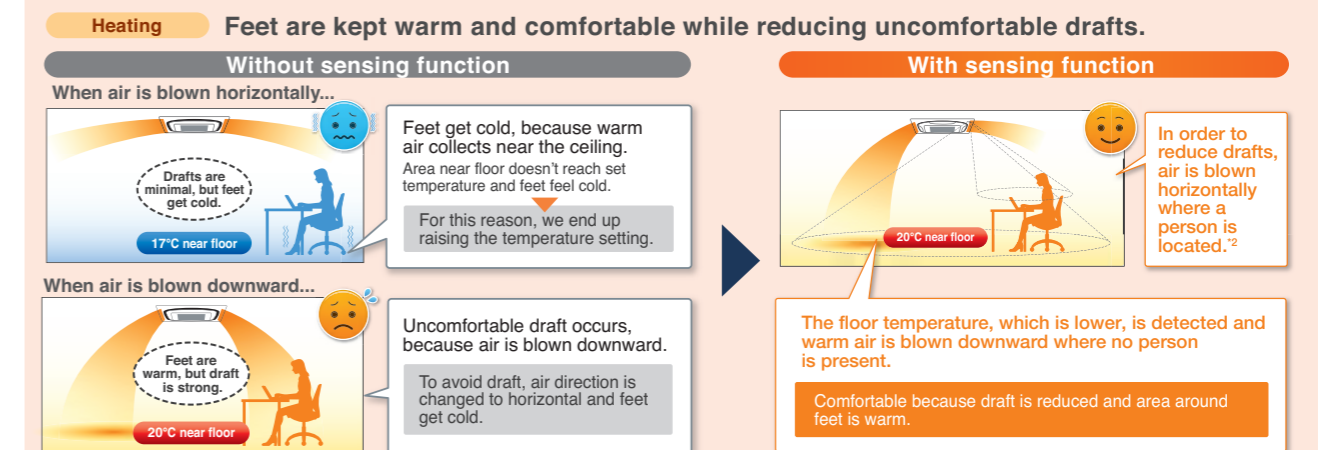

- The tendency of people to raise the temperature too much is prevented, because you are warmed up from the feet.

To increase comfort, Auto airflow rate mode controls the airflow in accordance with the difference between floor and ceiling temperatures.

When there is a large difference between the ceiling and floor temperatures, the airflow rate is automatically increased. When the difference becomes small, the airflow rate is automatically reduced.

*1. Both airflow direction and airflow rate should be set to Auto. *2. Draft prevention function is set OFF in the initial setting.

Indoor Unit Lineup

VRV Indoor Units

Ceiling Mounted Cassette (Round Flow with Sensing) Type

Sensing sensor mode*1,2

Sensing sensor low mode (default: OFF)

When there are no people in a room, the set temperature is shifted automatically.

The system automatically saves energy by detecting whether or not the room is occupied. The set temperature is shifted automatically if the room is unoccupied.

Operation is reduced in places where there are no people.

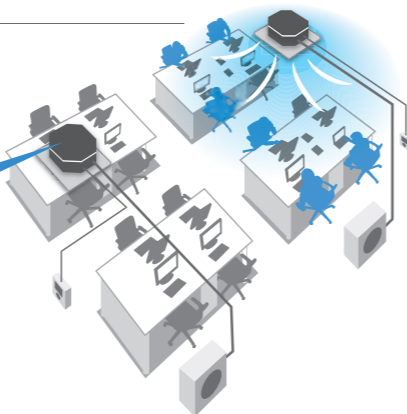

Example • Cooling setpoint: 26°C • Shift temperature: 1.0°C
• Shift time: 30 min. • Limit cooling temperature: 30°C

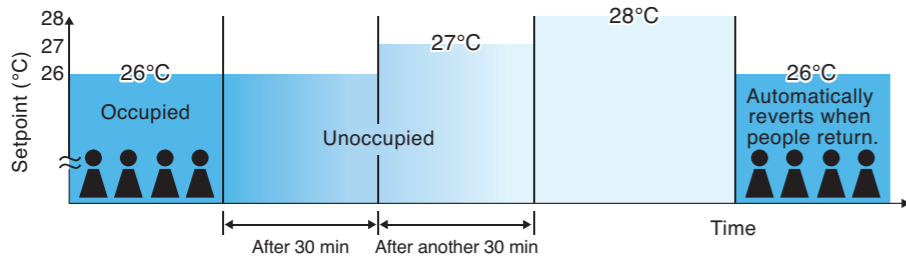

If people do not return, the air conditioner will raise the temperature 1°C every 30 minutes and then operate at 30°C.

Example • Heating setpoint: 20°C • Shift temperature: 1.0°C
• Shift time: 30 min. • Limit heating temperature: 16°C

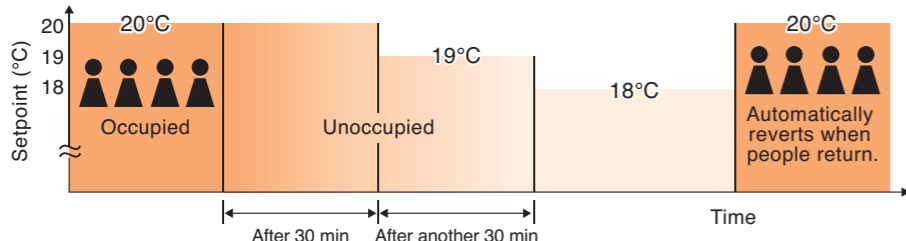

If people do not return, the air conditioner will lower the temperature 1°C every 30 minutes and then operate at 16°C.

Shift temperature and time can be selected from 0.5 to 4°C in 0.5°C increments and 15, 30, 45, 60, 90 or 120 minutes respectively with remote controller.

Sensing sensor stop mode (default: OFF)

When there are no people in a room, the system stops automatically.*3

The system automatically saves energy by detecting whether or not the room is occupied. Based on preset user conditions, the system automatically stops operation if the room is unoccupied.

Absent stop time can be selected from 1 to 24 hrs in 1 hr increments with remote controller.



*1. These functions are not available when using the group control system.
*2. User can set these functions with remote controller.
*3. Please note that upon re-entering the room, air conditioner will not switch on automatically.

Individual airflow direction control

Individual airflow setting

Airflow direction of each of the four air outlets can be controlled individually. (Positions 0 to 4, Swing, Blocked, and No individual setting are selectable.)

Example

Individual setting list		
Unit	Outletmark	Air direc. Indiv.
	<input type="checkbox"/>	blocked ON
	<input type="checkbox"/>	Auto OFF
	<input type="checkbox"/>	Position 2 ON
	<input type="checkbox"/>	Swing ON
	<input type="checkbox"/>	Return

Airflow block function*1

Total comfort by individual airflow direction control and "airflow block function"

- Airflow block function prevents uncomfortable drafts by reducing air velocity. It can be set using the BRC1E62 remote controller. There is no need for sealing material of air discharge outlet (option).
- This function only works when all-round flow is used. It cannot be used when sealing material is used in the air discharge outlet (option).

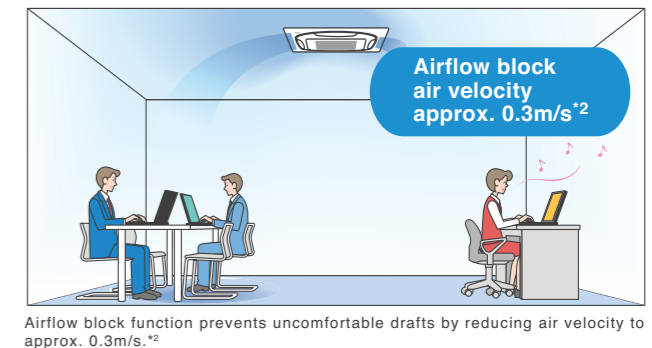

Airflow block function prevents uncomfortable drafts by reducing air velocity to approx. 0.3m/s.*2

Easy setup with remote controller

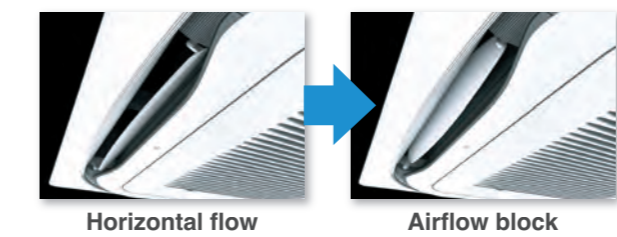

*1. Works in one direction only.
*2. In case of FXFQ63S type (Data is based on Daikin research.) When using FXFQ80S type or higher, if the airflow rate is set to High, airflow will be on the high side. Under actual conditions, however, the airflow value may differ depending on the effect of surrounding conditions and the way in which the temperature was adjusted.
*3. A gap of 1500 mm is required if the air block function is not used.

Indoor Unit Lineup

VRV Indoor Units

Ceiling Mounted Cassette (Round Flow) Type

FXFQ25LU / FXFQ32LU / FXFQ40LU
FXFQ50LU / FXFQ63LU / FXFQ80LU
FXFQ100LU / FXFQ125LU



360° airflow improves temperature distribution and offers a comfortable living environment.

- The industry's first* Round Flow Ceiling Mounted Cassette type offers 360° airflow with improved temperature distribution.

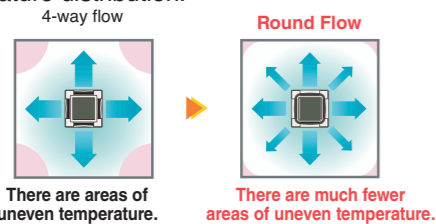

* As of April 2004, the release date for Japan.

- The light weight unit at 19.5 kg for FXFQ25-50LU models makes installation easy.

- Drain pump is equipped as a standard accessory with a 850 mm lift.

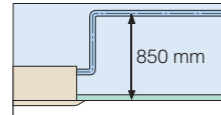

- A modern sophisticated decoration panel has been applied, with a panel surface that has been treated with a dirt-repellant coating.



- Control of the airflow rate can be selected from 3-step control.

- Low operation sound level

FXFQ-LU	25/32	40	50	63	80	100	125
Sound level (HH/H/L)	30/28.5/27	31/29/27	32/29.5/27	34/31/28	36/33.5/31	43/37.5/32	44/39/34

- Example of airflow patterns:

All-round flow is available, as well as 2-way to 4-way flows, so you can choose the most suitable airflow pattern depending on location or room layout.



Note: Whatever the discharge direction, the same type of panel is used. If installing for other than all-round flow, an air discharge outlet sealing material (option) must be used to close each unused outlet.

Ceiling Mounted Cassette (Compact Multi Flow) Type

FXZQ20M / FXZQ25M / FXZQ32M
FXZQ40M / FXZQ50M



Quiet, compact, and designed for user comfort

- Dimensions correspond with 600 mm x 600 mm architectural module ceiling design specifications.

- Low operation sound level

FXZQ-M	20/25	32	40	50
Sound level (H/L)	30/25	32/26	36/28	41/33

(230 V)(dB(A))

- Comfortable airflow

- Wide discharge angle: 0° to 60°

- Auto swing

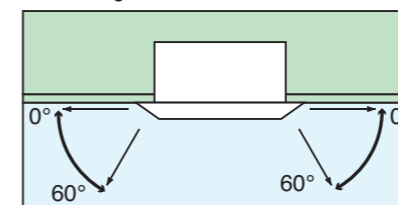

- Fixed angles: 5 levels

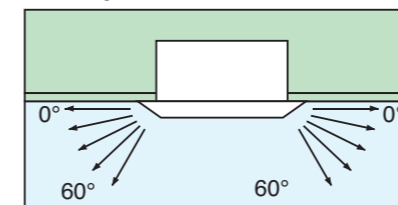

*Angles can be also set on site to prevent drafts (0°-35°) or soiling of the ceiling (25°-60°), other than standard setting (0°-60°).

- 2-, 3-, and 4-way airflow patterns are available, enabling installation in the corner of a room.

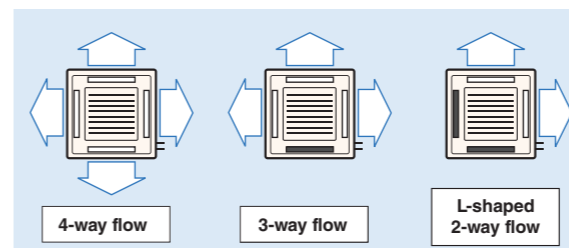

*For 3-way or 2-way flow installation, the sealing material for air discharge outlet (option) must be used to close each unused outlet.



- Drain pump is equipped as standard accessory with 750 mm lift.

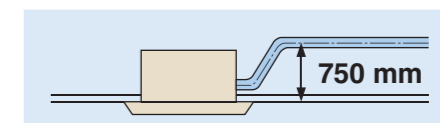

Indoor Unit Lineup

VRV Indoor Units

4-Way Flow Ceiling Suspended Type

FXUQ71A / FXUQ100A



This slim and stylish indoor unit achieves optimum air distribution, and can be installed without the need for ceiling cavity.

- Unit body and suction panel adopted round shapes and realised a slim appearance design. The unit can be used for various locations such as the ceilings with no cavity and bare ceilings.



- Flaps close automatically when the unit stops, which gives a simple appearance.

- Unified slim height of 198 mm for all models that gives the unified impression even when models with different capacities are installed in the same area.

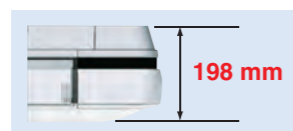

- Built-in electronic expansion valve eliminates the need for a BEV unit, which improves flexibility of installation.

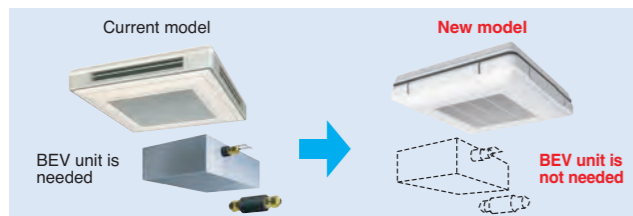

- With adoption of the individual flap control, airflow direction adjustment can be individually set for each air outlet. 5 directions of airflow and auto-swing can be selected with wired remote controller BRC1E62, which realises the optimum air distribution.

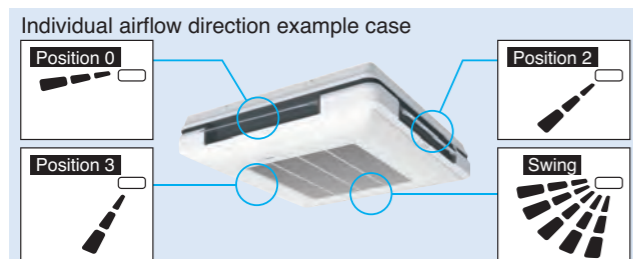

- Control of the airflow rate has been improved from 2-step to 3-step control. Auto airflow rate control can be selected with wired remote controller BRC1E62.

- Energy efficiency has been improved thanks to the adoption of a new heat exchanger with smaller tubes, DC fan motor and DC drain pump motor.

- Drain pump is equipped as a standard accessory, and the lift height has been improved from 500 mm to 600 mm.

- Depending on installation site requirements or room conditions, 2-way, 3-way and 4-way discharge patterns are available.

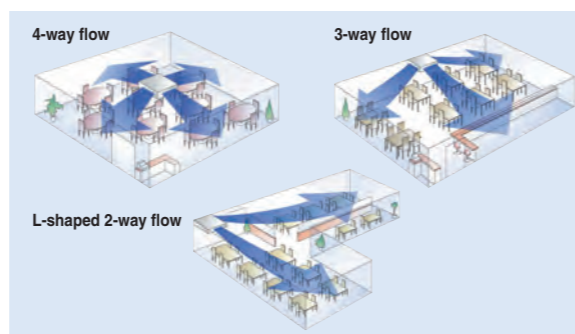

Ceiling Mounted Cassette (Double Flow) Type

FXCQ20M / FXCQ25M / FXCQ32M
FXCQ40M / FXCQ50M / FXCQ63M
FXCQ80M / FXCQ125M



Thin, lightweight, and easy to install in narrow ceiling spaces

- The thin unit (only 305 mm high) can be installed in a ceiling space as narrow as 350 mm. All models feature a compact design with a depth of only 600 mm.

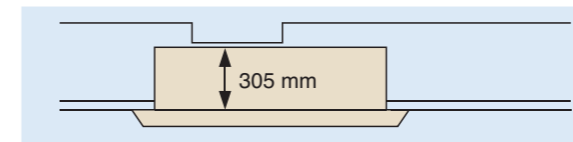

(When a high-efficiency filter is attached, the unit's height is 400 mm.)

- Low operation sound level

FXCQ-M	20	25/32	40/50	63	80	125
Sound level (H/L)	32/27	34/28	34/29	37/32	39/34	44/38

(220 V)(dB(A))

- Designed with higher airflow suitable for high ceiling application up to 3 metres.

- Providing 2 different settings of standard and ceiling soiling prevention, the auto swing mechanism realises even distribution of airflow and room temperature.

- Drain pump is equipped as standard accessory with 600 mm lift.

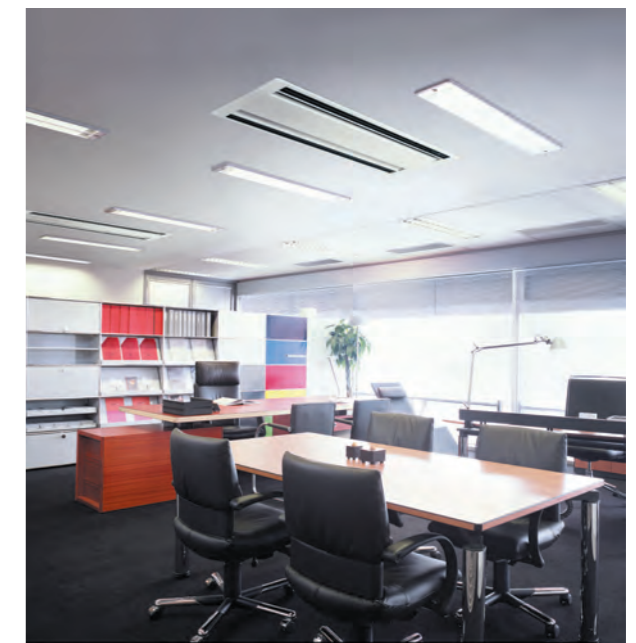
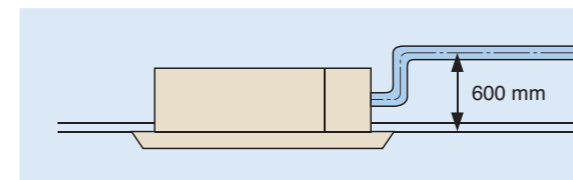

- Two types of optional high-efficiency filter are available (65% and 95%, colourimetric method).

- A long-life filter (maintenance free up to one year*) is equipped as standard accessory.

* 8 hr/day, 25 day/month. For dust concentration of 0.15 mg/m³

- Major maintenance work can be performed by removing the panel. A flat-type suction grille and a detachable blade make cleaning easy.

Indoor Unit Lineup

VRV Indoor Units

Ceiling Mounted Cassette Corner Type

FXKQ25MA / FXKQ32MA
FXKQ40MA / FXKQ63MA



Slim design for flexible installation

- Slim body needs only 220 mm space above the ceiling. If you use a panel spacer (option), the unit can be installed in the minimum space of 195 mm.

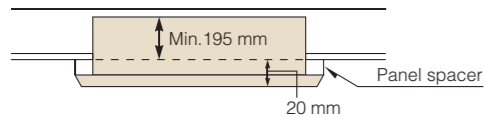

- Single-flow type allows effective air discharge from corner or from drop-ceiling.

- Drain pump is equipped as standard accessory with 500 mm lift.

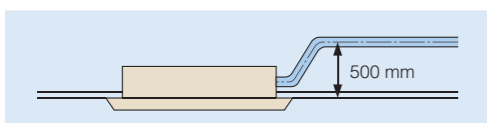

- Providing 3 different settings of standard, draft prevention and ceiling soiling prevention, the auto swing mechanism realises even distribution of airflow and room temperature.

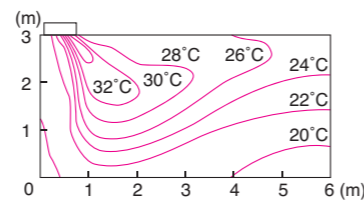

- Front discharge is possible with an air discharge unit (option), which allows the installation in the drop-ceiling or sagging wall.

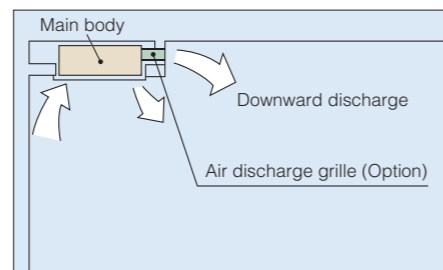

*Set for front discharge using a suspended ceiling.

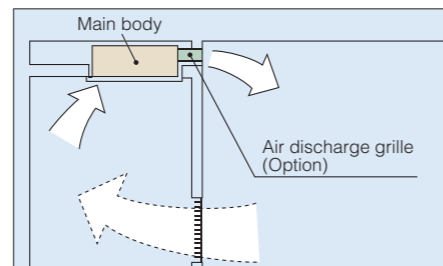

*Downward discharge is shut off and air is blown straight out (front discharge).

- A long-life filter (maintenance free up to one year*) is equipped as standard accessory.

* 8 hr/day, 25 day/month. For dust concentration of 0.15 mg/m³

Slim Ceiling Mounted Duct Type

Slim design, quietness and static pressure switching

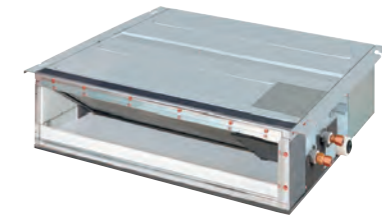

Suited to use in drop-ceilings!

FXDQ20PB / FXDQ25PB / FXDQ32PB

- Only 700 mm in width and 23 kg in weight, this model is suitable to install in limited spaces like drop-ceilings in hotels.

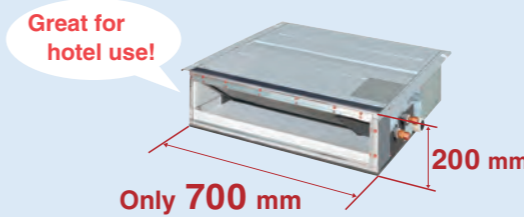

FXDQ40NB / FXDQ50NB / FXDQ63NB

- Only 200 mm in height, this model can be installed in rooms with as little as 240 mm in height for the ceiling space between the drop-ceiling and ceiling slab.

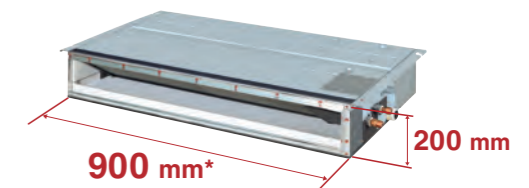

* 1,100 mm in width for the FXDQ63NB model.

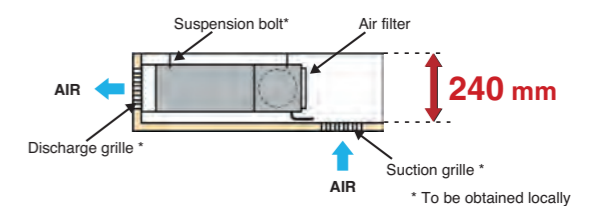

* To be obtained locally

- External static pressure selectable by remote controller switching make this indoor unit a very comfortable and flexible model.

10 Pa-30 Pa/factory set: 10 Pa for FXDQ-PB models.
15 Pa-44 Pa/factory set: 15 Pa for FXDQ-NB models.

- FXDQ-PB and FXDQ-NB models are available in two types to suit different installation conditions.

FXDQ-PB/NBVE: with a drain pump (750 mm lift) as a standard accessory

FXDQ-PB/NBVET: without a drain pump

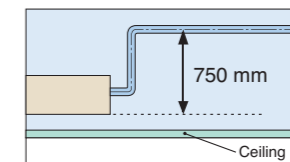

- Control of the airflow rate has been improved from 2-step to 3-step control.

● Low operation sound level (dB (A))

FXDQ-PB/NB	20/25	32	40	50	63
Sound level (HH/H/L)	28/26/23	28/26/24	30/28/26	33/30/27	33/31/29

* The values of operation sound level represent those for rear-suction operation. Sound level values for bottom-suction operation can be obtained by adding 5 dB(A).
* Values are based on the following conditions:
FXDQ-PB: external static pressure of 10 Pa; FXDQ-NB: external static pressure of 15 Pa.

Indoor Unit Lineup

VRV Indoor Units

Middle Static Pressure Ceiling Mounted Duct Type

New

FXSQ20P / FXSQ25P / FXSQ32P
FXSQ40P / FXSQ50P / FXSQ63P
FXSQ80P / FXSQ100P
FXSQ125P / FXSQ140P



Middle external static pressure and slim design allow flexible installations

Installation flexibility

Slim design

- With a height of only 245 mm, installation is possible even in buildings with narrow ceiling spaces.

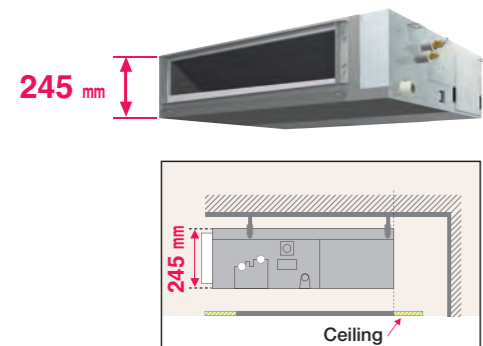

Bottom suction possible

- Bottom suction is possible which facilitates installation and maintenance. Wiring connections and maintenance of control box can be done from under the unit with an optional shield plate for side plate*, extending the degree of freedom for installation in the ceiling.

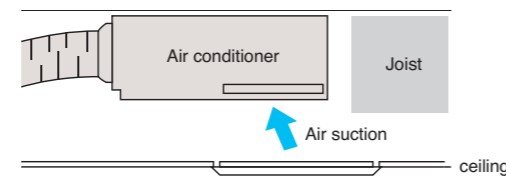

- Air suction direction can be altered from rear to bottom suction.

Rear suction

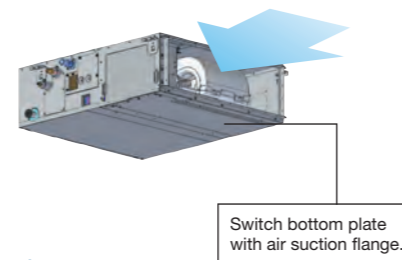

Bottom suction

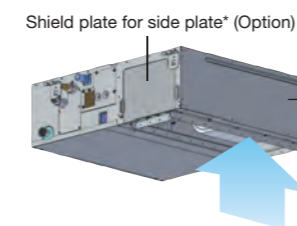

*An optional shield plate for side plate is required if wiring connections and maintenance of control box are needed from under the unit. This option is only available for FXSQ20-125P models.

Standard DC drain pump

- DC drain pump is equipped as standard accessory with 850 mm lift.

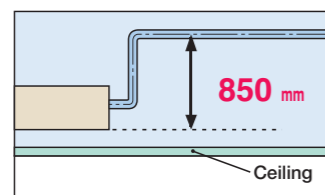

Design flexibility

Adjustable external static pressure

- Using a DC fan motor, the external static pressure can be controlled within a range of 30 Pa* to 150 Pa.

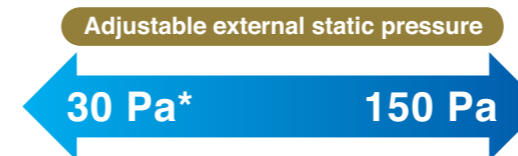

Set to low static pressure when ducts are short.

Set to high static pressure for advanced needs such as when using dampers and long ducts.

Comfortable airflow is achieved in accordance with conditions such as duct length.

*30 Pa–150 Pa for FXSQ20–40PVE
50 Pa–150 Pa for FXSQ50–125PVE
50 Pa–140 Pa for FXSQ140PVE

Comfort

Switchable airflow rate

- Control of the airflow rate can be selected from 3-step control.

Auto airflow rate

- 5-step airflow rate is automatically controlled in accordance with the difference between room temperature and set temperature. Auto airflow rate control can be selected with wired remote controller BRC1E62.

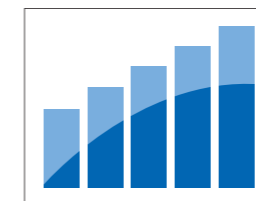

Low operation sound level

	(dB(A))				
FXSQ-PVE	20/25	32	40	50	63
Sound level (H/M/L)	33/30/28	34/32/30	36/33/30	34/32/29	36/32/29
FXSQ-PVE	80	100	125	140	
Sound level (H/M/L)	37.5/34/30	39/35/32	42/38.5/35	43/40/36	



Easy installation

Airflow rate auto adjustment function

- During installation, even if the external static pressure changes due to a change in the duct route, the airflow can be automatically adjusted to within the unit's external static pressure range.

- Airflow rate can be controlled using a remote controller during test operation. It is automatically adjusted to the range between approximately ±10% of the rated H tap airflow.

Easy maintenance

- Inspection and cleaning is facilitated by separating the drain pipe and inspection opening and by the drain pan maintenance check hole.

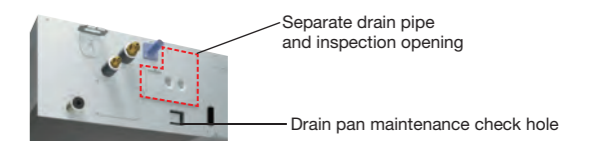

- The drain pan can be detached for easy cleaning. An antibacterial treatment that uses silver ions has been applied to the drain pan, preventing the growth of slime, mould and bacteria that cause blockages and odours.

Indoor Unit Lineup

VRV Indoor Units

Ceiling Mounted Duct Type

FXMQ20P / FXMQ25P / FXMQ32P
 FXMQ40P / FXMQ50P / FXMQ63P
 FXMQ80P / FXMQ100P / FXMQ125P
 FXMQ140P



Middle and high static pressure allows for flexible duct design

- A DC fan motor increases the external static pressure capacity range to include middle to high static pressures, increasing design flexibility.

30 Pa–100 Pa for FXMQ20P–32P
 30 Pa–160 Pa for FXMQ40P
 50 Pa–200 Pa for FXMQ50P–125P
 50 Pa–140 Pa for FXMQ140P

- All models are only 300 mm in height, an improvement over the 390 mm height of conventional models. The weight of the FXMQ40P has been reduced from 44 kg to 28 kg.

- Drain pump is equipped as standard accessory with 700 mm lift.

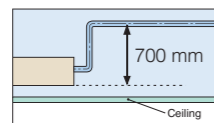

- Control of the airflow rate has been improved from 2-step to 3-step control.

- Low operation sound level

FXMQ-P	20/25	32	40	50	63	80/100	125	140
Sound level (HH/H/L)	33/31/29	34/32/30	39/37/35	41/39/37	42/40/38	43/41/39	44/42/40	46/45/43

- Energy-efficient

- The adopted DC fan motor is much more efficient than the conventional AC motor, yielding an approximate 20% decrease in energy consumption (FXMQ125P).



- Improved ease of installation

- Airflow rate can be controlled using a remote controller during test operation. With the conventional model, the airflow rate was controlled from the PC board. It is automatically adjusted to the range between approximately ±10% of the rated HH tap airflow for FXMQ20P–125P.

- Improved ease of maintenance

- The drain pan can be detached for easy cleaning. An antibacterial treatment that uses silver ions has been applied to the drain pan, preventing the growth of slime, mould and bacteria that cause blockages and odours.

FXMQ200MA/FXMQ250MA



- Simplified Static Pressure Control

External static pressure can be easily adjusted using a change-over switch inside the electrical box to meet the resistance in the duct system.

- Built-in Drain Pump (Option)

Housing the drain pump inside the unit reduces the space required for installation.

- Without drain pump

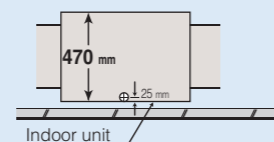

- With drain pump

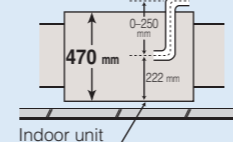

Ceiling Suspended Type

FXHQ32MA / FXHQ63MA
 FXHQ100MA

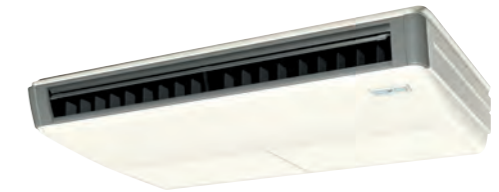

Slim body with quiet and wide airflow

- Adoption of QUIET STREAM FAN

Uses the quiet stream fan and many more advanced technologies.

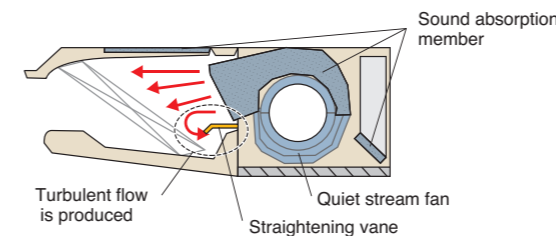

- Low operation sound level

FXHQ-MA	32	63	100
Sound level (H/L)	36/31	39/34	45/37

- Installation is easy

- Drain pump kit (option) can be easily incorporated.

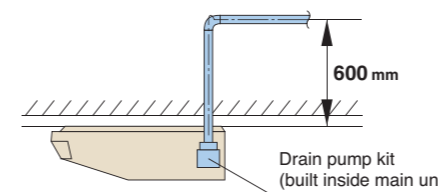

- Wide air discharge openings produce a spreading 100° airflow.

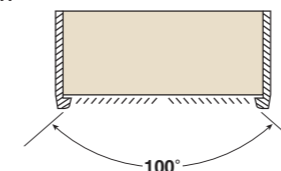

- Maintenance is easy

- Non-dew Flap with no implanted bristles

Bristle-free Flap minimises contamination and makes cleaning simpler.



Non-dew Flap

- Easy-to-clean flat design

- Maintenance is easier because everything can be performed from below the unit.

- A long-life filter (maintenance free up to one year*) is equipped as standard accessory.

* 8 hr/day, 25 day/month. For dust concentration of 0.15 mg/m³

Indoor Unit Lineup

VRV Indoor Units

Wall Mounted Type

FXAQ20P / FXAQ25P
FXAQ32P / FXAQ40P
FXAQ50P / FXAQ63P



Stylish flat panel design harmonised with your interior décor

- Stylish flat panel design creates a graceful harmony that enhances any interior space.

- Flat panel can be cleaned with only the single pass of a cloth across their smooth surface. Flat panel can also be easily removed and washed for more thorough cleaning.

- Low operation sound level (dB(A))

FXAQ-P	20	25	32	40	50	63
Sound level (H/L)	35/31	36/31	38/31	39/34	42/37	47/41

- Drain pan and air filter can be kept clean by mould-proof polystyrene.

- Vertical auto-swing realises efficiency of air distribution. The louvre closes automatically when the unit stops.

- 5 steps of discharge angle can be set by remote controller.

- Discharge angle is automatically set at the same angle as the previous operation when restarting. (Initial setting: 10° for cooling and 70° for heating)

- Flexible installation
 - Drain pipe can be fitted to from either left or right sides.



- Drain pump kit is available as optional accessory, which lifts the drain 1,000 mm from the bottom of the unit.

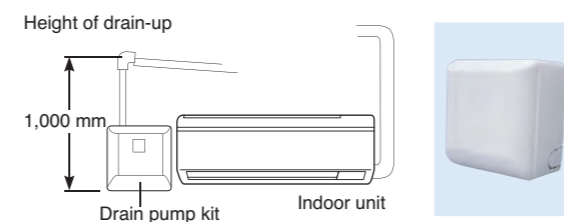

Floor Standing Type

FXLQ20MA / FXLQ25MA
FXLQ32MA / FXLQ40MA
FXLQ50MA / FXLQ63MA



Suitable for perimeter zone air conditioning

- Floor Standing types can be hung on the wall for easier cleaning. Running the piping from the back allows the unit to be hung on walls. Cleaning under the unit, where dust tends to accumulate, is considerably easier.
- The adoption of a fibre-less discharge grille featuring an original design to prevent condensation also helps prevent staining and makes cleaning easier.
- A long-life filter (maintenance free up to one year*) is equipped as standard accessory.

* 8 hr/day, 25 day/month. For dust concentration of 0.15 mg/m³

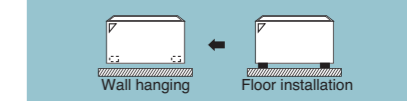

Concealed Floor Standing Type

FXNQ20MA / FXNQ25MA
FXNQ32MA / FXNQ40MA
FXNQ50MA / FXNQ63MA



Designed to be concealed in the perimeter skirting-wall

- The unit is concealed in skirting-wall of perimeter, that enables to create high class interior design.

- The connecting port faces downward, greatly facilitating on-site piping work.

- A long-life filter (maintenance free up to one year*) is equipped as standard accessory.

* 8 hr/day, 25 day/month. For dust concentration of 0.15 mg/m³

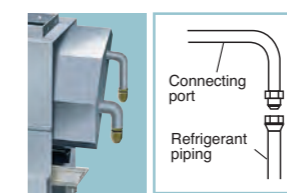

* Applies also to Floor Standing type (FXLQ-MA).



Indoor Unit Lineup

Residential Indoor Units with Connection to BP Units

Slim Ceiling Mounted Duct Type



CDXS25EA / CDXS35EA
FDXS25C / FDXS35C
FDXS50C / FDXS60C

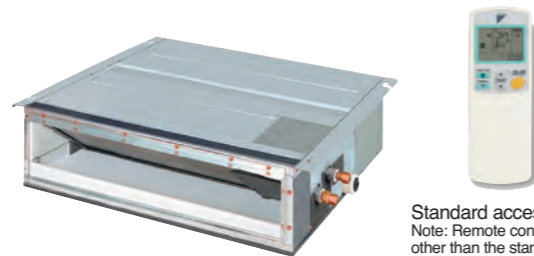

Standard accessory
Note: Remote controllers other than the standard accessory wireless remote controller cannot be used.

Slim and smooth design suits your shallow ceiling

- Models in the CDXS-EA series are only 700 mm in width and 21 kg in weight, so are easily installed in limited spaces. Just 200 mm in height, all models can be installed in rooms with as little as 240 mm depth between the drop ceiling and ceiling slab, making them ideal for even shallow ceilings.

Great for hotel use!

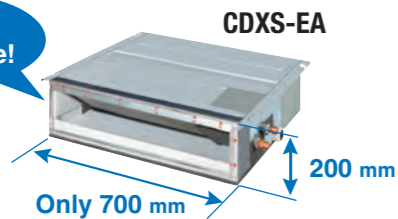

	CDXS25EA	CDXS35EA	FDXS25C	FDXS35C
Dimensions (H x W x D)	200 x 700 x 620 mm		200 x 900 x 620 mm	
Weight	21 kg		25 kg	
Airflow rate (H)	8.7 m ³ /min		9.5 m ³ /min	10 m ³ /min
External static pressure	30 Pa		40 Pa	

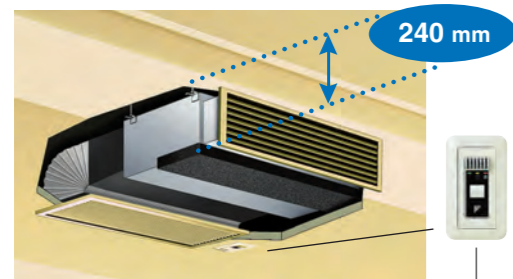

Signals from the wireless remote controller are transmitted to the signal receiver.

- Low operation sound level (H/L/SL)

C(F)DXS25	C(F)DXS35	FDXS50	FDXS60
35/31/29 dB (A)	35/31/29 dB (A)	37/33/31 dB (A)	38/34/32 dB (A)

- Home Leave Operation prevents large rises or falls in the indoor temperature by continuing operation* while you are sleeping or out of your home. This means that an air-conditioned welcome awaits when you wake or return. It also means that the indoor temperature can quickly return to your favourite comfort setting.

* Home Leave Operation can be selected for any temperature from 18 to 32°C for cooling operation and 10 to 30°C for heating operation.
* Home Leave Operation function must be set using the remote controller when going to sleep or leaving the house, and after waking up or returning home.

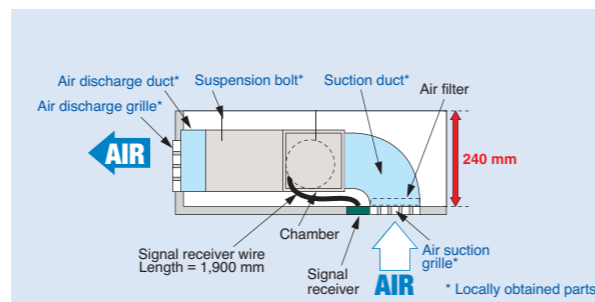

Notes:
1. To prevent an increase in operation noise, avoid installing the air suction grille directly below the suction chamber.
2. Grilles, piping connections, ducts, and installation parts should be obtained locally. Slim Ceiling Mounted Duct type models do not have drain-up pumps.
3. The signal receiver unit must be located near the air suction inlet, because the unit includes a sensor that detects room temperature.

Wall Mounted Type



FTXS20D / FTXS25E / FTXS35E



Standard accessory*

FTXS50F / FTXS60F / FTXS71F



Standard accessory*

* Remote controllers other than the standard accessory wireless remote controller cannot be used.

Stylish flat panel harmonises with your interior décor

- Wall Mounted indoor units achieve quiet sound levels of 22 dB (A) during cooling operation.

FTXS20/25	FTXS35	FTXS50	FTXS60	FTXS71
37/25/22 dB (A)	39/26/23 dB (A)	43/34/31 dB (A)	45/36/33 dB (A)	46/37/34 dB (A)

- Intelligent Eye with its infrared sensor automatically controls air conditioner operation according to human movement in a room. When there is no movement, it adjusts the temperature by 2°C for energy savings.

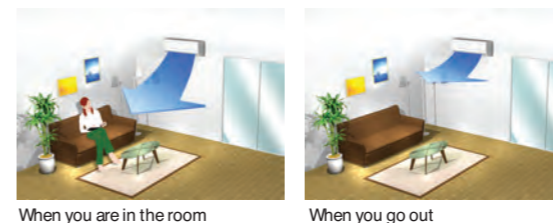

- Comfort Airflow Mode prevents uncomfortable drafts from blowing directly on to your body. With this function, when you press the COMFORT button during cooling operation, the flap moves upward to prevent direct cold drafts. During heating operation, it also moves downward to prevent direct drafts and deliver warm air to the floor.

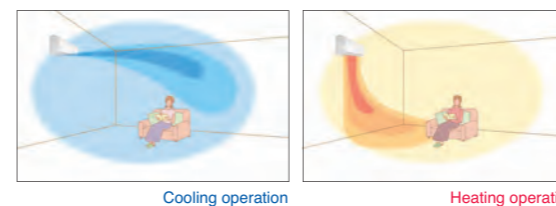

- Titanium apatite is a photocatalytic material with high adsorption power. Titanium apatite also effectively adsorbs and decomposes bacteria across its entire surface. The photocatalyst is activated simply by exposure to light.

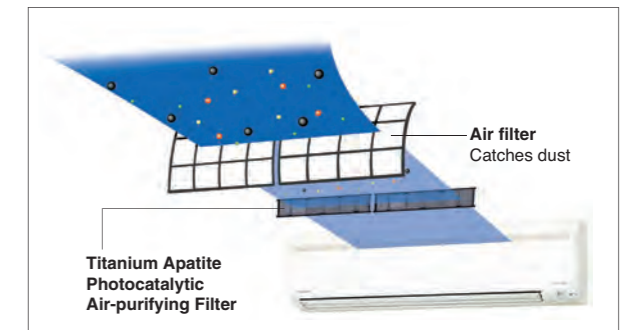

These filters are not medical devices. Benefits such as the adsorption and decomposition of bacteria are only effective for substances that are collected on and in direct contact with the Titanium Apatite Photocatalytic Air-Purifying Filter.

Bacteria Removal Test
Testing method: dropping method
Result certificate: No. 012553-1 and 012553-2
Testing organisation: Japan Spinners Inspecting Foundation



Specifications

VRV Indoor Units

Ceiling Mounted Cassette (Round Flow with Sensing) Type



MODEL		FXFQ25SVM	FXFQ32SVM	FXFQ40SVM	FXFQ50SVM	FXFQ63SVM	FXFQ80SVM	FXFQ100SVM	FXFQ125SVM	
Power supply		1-phase, 220-240 V/220-230 V, 50/60 Hz								
Cooling capacity	kcal/h	2,400	3,100	3,900	4,800	6,100	7,700	9,600	12,000	
	Btu/h	9,600	12,300	15,400	19,100	24,200	30,700	38,200	47,800	
	kW	2.8	3.6	4.5	5.6	7.1	9.0	11.2	14.0	
Heating capacity	kcal/h	2,800	3,400	4,300	5,400	6,900	8,600	10,800	13,800	
	Btu/h	10,900	13,600	17,100	21,500	27,300	34,100	42,700	54,600	
	kW	3.2	4.0	5.0	6.3	8.0	10.0	12.5	16.0	
Power consumption	Cooling	kW	0.031	0.031	0.041	0.080	0.095	0.095	0.194	0.219
	Heating	kW	0.027	0.027	0.037	0.075	0.090	0.090	0.180	0.199
Casing		Galvanised steel plate								
Airflow rate (H/M/L)	m ³ /min	12.5/11.5/10.0	12.5/11.5/10.0	14.5/13.0/11.0	22.0/17.5/13.5	23.5/18.5/13.5	23.5/19.5/15.0	33.0/26.0/19.0	34.5/27.5/21.0	
	cfm	441/406/353	441/406/353	512/459/388	777/618/477	830/653/477	830/688/530	1,165/918/671	1,218/971/741	
Sound level (H/M/L)	dB(A)	30/28.5/27	30/28.5/27	31/29/27	36/32/28	38/33/28	38/35/31	44/38/32	45/40/35	
Dimensions (HxWxD)	mm	246x840x840						288x840x840		
Machine weight	kg	19			23			26		
Piping connections	Liquid (Flare)	φ6.4			φ9.5					
	Gas (Flare)	φ12.7			φ15.9					
	Drain	VP25 (External Dia, 32/Internal Dia, 25)								
Panel (Option)	Model	BYCQ125B-W1								
	Colour	Fresh white								
	Dimensions(HxWxD)	50x950x950								
	Weight	5.5								

Ceiling Mounted Cassette (Round Flow) Type



MODEL		FXFQ25LUV1	FXFQ32LUV1	FXFQ40LUV1	FXFQ50LUV1	FXFQ63LUV1	FXFQ80LUV1	FXFQ100LUV1	FXFQ125LUV1	
Power supply		1-phase, 220-240 V, 50 Hz								
Cooling capacity	kcal/h	2,400	3,100	3,900	4,800	6,100	7,700	9,600	12,000	
	Btu/h	9,600	12,300	15,400	19,100	24,200	30,700	38,200	47,800	
	kW	2.8	3.6	4.5	5.6	7.1	9.0	11.2	14.0	
Heating capacity	kcal/h	2,800	3,400	4,300	5,400	6,900	8,600	10,800	13,800	
	Btu/h	10,900	13,600	17,100	21,500	27,300	34,100	42,700	54,600	
	kW	3.2	4.0	5.0	6.3	8.0	10.0	12.5	16.0	
Power consumption	Cooling	kW	0.033	0.033	0.047	0.052	0.066	0.093	0.187	0.209
	Heating	kW	0.027	0.027	0.034	0.038	0.053	0.075	0.174	0.200
Casing		Galvanised steel plate								
Airflow rate (HH/H/L)	m ³ /min	13/11.5/10	13/11.5/10	15/13/11	16/13.5/11	19/16.5/13.5	21/18/15	32/26/20	33/28/22.5	
	cfm	459/406/353	459/406/353	530/459/388	565/477/388	671/583/477	742/636/530	1,130/918/706	1,165/989/794	
Sound level (HH/H/L)	dB(A)	30/28.5/27	30/28.5/27	31/29/27	32/29.5/27	34/31/28	36/33.5/31	43/37.5/32	44/39/34	
Dimensions (HxWxD)	mm	246x840x840						288x840x840		
Machine weight	kg	19.5			22			25		
Piping connections	Liquid (Flare)	φ6.4			φ9.5					
	Gas (Flare)	φ12.7			φ15.9					
	Drain	VP25 (External Dia, 32/Internal Dia, 25)								
Panel (Option)	Model	BYCP125K-W1								
	Colour	Fresh white								
	Dimensions(HxWxD)	50x950x950								
	Weight	5.5								

Note: Specifications are based on the following conditions:
 • Cooling: Indoor temp.: 27°CDB, 19°CWB, Outdoor temp.: 35°CDB, Equivalent piping length: 7.5 m, Level difference: 0 m.
 • Heating: Indoor temp.: 20°CDB, Outdoor temp.: 7°CDB, 6°CDB, Equivalent piping length: 7.5 m, Level difference: 0 m.
 • Capacity of indoor unit is only for reference. Actual capacity of indoor unit is based on the total capacity index.
 (See Engineering Data Book for details.)
 • Sound level: Anechoic chamber conversion value, measured at a point 1.5 m downward from the unit centre.
 During actual operation, these values are normally somewhat higher as a result of ambient conditions.

Ceiling Mounted Cassette (Compact Multi Flow) Type

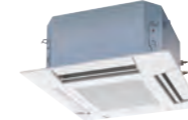

MODEL		FXZQ20MVE	FXZQ25MVE	FXZQ32MVE	FXZQ40MVE	FXZQ50MVE	
Power supply		1-phase, 220-240 V/220 V, 50/60 Hz					
Cooling capacity	kcal/h	1,900	2,400	3,100	3,900	4,800	
	Btu/h	7,500	9,600	12,300	15,400	19,100	
	kW	2.2	2.8	3.6	4.5	5.6	
Heating capacity	kcal/h	2,200	2,800	3,400	4,300	5,400	
	Btu/h	8,500	10,900	13,600	17,100	21,500	
	kW	2.5	3.2	4.0	5.0	6.3	
Power consumption	Cooling	kW	0.073		0.076	0.089	0.115
	Heating	kW	0.064		0.068	0.080	0.107
Casing		Galvanised steel plate					
Airflow rate (H/L)	m ³ /min	9/7		9.5/7.5	11/8	14/10	
	cfm	318/247		335/265	388/282	493/353	
Sound level (H/L)	230 V	30/25		32/26	36/28	41/33	
	240 V	32/26		34/28	37/29	42/35	
Dimensions (HxWxD)	mm	286x575x575					
Machine weight	kg	18					
Piping connections	Liquid (Flare)	φ6.4					
	Gas (Flare)	φ12.7					
	Drain	VP20 (External Dia, 26/Internal Dia, 20)					
Panel (Option)	Model	BYFQ60B3W1					
	Colour	White (6.5Y9.5/0.5)					
	Dimensions(HxWxD)	55x700x700					
	Weight	2.7					

4-Way Flow Ceiling Suspended Type



MODEL		FXUQ71AVEB	FXUQ100AVEB	
Power supply		1-phase, 220-240 V/220-230 V, 50/60 Hz		
Cooling capacity	kcal/h	6,900	9,600	
	Btu/h	27,300	38,200	
	kW	8.0	11.2	
Heating capacity	kcal/h	7,700	10,800	
	Btu/h	30,700	42,700	
	kW	9.0	12.5	
Power consumption	Cooling	kW	0.090	0.200
	Heating	kW	0.073	0.179
Casing		Fresh white		
Airflow rate (H/M/L)	m ³ /min	22.5/19.5/16	31/26/21	
	cfm	794/688/565	1,094/918/741	
Sound level (H/M/L)	dB(A)	40/38/36	47/44/40	
Dimensions (HxWxD)	mm	198x950x950		
Machine weight	kg	26	27	
Piping connections	Liquid (Flare)	φ9.5		
	Gas (Flare)	φ15.9		
	Drain	VP20 (External Dia, 26/Internal Dia, 20)		

Note: Specifications are based on the following conditions:
 • Cooling: Indoor temp.: 27°CDB, 19°CWB, Outdoor temp.: 35°CDB, Equivalent piping length: 7.5 m, Level difference: 0 m.
 • Heating: Indoor temp.: 20°CDB, Outdoor temp.: 7°CDB, 6°CDB, Equivalent piping length: 7.5 m, Level difference: 0 m.
 • Capacity of indoor unit is only for reference. Actual capacity of indoor unit is based on the total capacity index.
 (See Engineering Data Book for details.)
 • Sound level: (FXZQ-M) Anechoic chamber conversion value, measured at a point 1.5 m downward from the unit centre.
 (FXUQ-A) Anechoic chamber conversion value, measured at a point 1 m in front of the unit and 1 m downward.
 During actual operation, these values are normally somewhat higher as a result of ambient conditions.

Specifications

VRV Indoor Units

Ceiling Mounted Cassette (Double Flow) Type



MODEL		FXCQ20MVE	FXCQ25MVE	FXCQ32MVE	FXCQ40MVE	FXCQ50MVE	FXCQ63MVE	FXCQ80MVE	FXCQ125MVE	
Power supply		1-phase, 220-240 V/220 V, 50/60 Hz								
Cooling capacity	kcal/h	1,900	2,400	3,100	3,900	4,800	6,100	7,700	12,000	
	Btu/h	7,500	9,600	12,300	15,400	19,100	24,200	30,700	47,800	
	kW	2.2	2.8	3.6	4.5	5.6	7.1	9.0	14.0	
Heating capacity	kcal/h	2,200	2,800	3,400	4,300	5,400	6,900	8,600	13,800	
	Btu/h	8,500	10,900	13,600	17,100	21,500	27,300	34,100	54,600	
	kW	2.5	3.2	4.0	5.0	6.3	8.0	10.0	16.0	
Power consumption	Cooling	kW	0.077	0.092	0.092	0.130	0.130	0.161	0.209	0.256
	Heating	kW	0.044	0.059	0.059	0.097	0.097	0.126	0.176	0.223
Casing		Galvanised steel plate								
Airflow rate (HH/M/L)	m ³ /min	7/5	9/6.5	9/6.5	12/9	12/9	16.5/13	26/21	33/25	
	cfm	247/177	318/230	318/230	424/318	424/318	582/459	918/741	1,165/883	
Sound level (H/L)	220 V	dB(A)	32/27	34/28	34/28	34/29	34/29	37/32	39/34	44/38
	240 V	dB(A)	34/29	36/30	36/30	37/32	37/32	39/34	41/36	46/40
Dimensions (HxWxD)	mm	305x775x600	305x775x600	305x775x600	305x990x600	305x990x600	305x1,175x600	305x1,665x600	305x1,665x600	
Machine weight	kg	26.0	26.0	26.0	31.0	32.0	35.0	47.0	48.0	
Piping connections	Liquid (Flare)	mm	φ6.4	φ6.4	φ6.4	φ6.4	φ6.4	φ9.5	φ9.5	
	Gas (Flare)	mm	φ12.7	φ12.7	φ12.7	φ12.7	φ12.7	φ15.9	φ15.9	
	Drain	VP25 (External Dia, 32/Internal Dia, 25)								
Panel (Option)	Model	BYBC32G-W1		BYBC50G-W1		BYBC63G-W1		BYBC125G-W1		
	Colour	White (10Y9/0.5)								
	Dimensions(HxWxD)	mm	53x1,030x680	53x1,030x680	53x1,030x680	53x1,245x680	53x1,245x680	53x1,430x680	53x1,920x680	
	Weight	kg	8.0	8.0	8.0	8.5	8.5	9.5	12.0	12.0

Ceiling Mounted Cassette Corner Type



MODEL		FXKQ25MAVE	FXKQ32MAVE	FXKQ40MAVE	FXKQ63MAVE	
Power supply		1-phase, 220-240 V/220 V, 50/60 Hz				
Cooling capacity	kcal/h	2,400	3,100	3,900	6,100	
	Btu/h	9,600	12,300	15,400	24,200	
	kW	2.8	3.6	4.5	7.1	
Heating capacity	kcal/h	2,800	3,400	4,300	6,900	
	Btu/h	10,900	13,600	17,100	27,300	
	kW	3.2	4.0	5.0	8.0	
Power consumption	Cooling	kW	0.066	0.066	0.076	0.105
	Heating	kW	0.046	0.046	0.056	0.085
Casing		Galvanised steel plate				
Airflow rate (H/L)	m ³ /min	11/9	11/9	13/10	18/15	
	cfm	388/318	388/318	459/353	635/530	
Sound level (H/L)	220 V	dB(A)	38/33	38/33	40/34	42/37
	240 V	dB(A)	40/35	40/35	42/36	44/39
Dimensions (HxWxD)	mm	215x1,110x710	215x1,110x710	215x1,110x710	215x1,310x710	
Machine weight	kg	31	31	31	34	
Piping connections	Liquid (Flare)	mm	φ6.4	φ6.4	φ6.4	φ9.5
	Gas (Flare)	mm	φ12.7	φ12.7	φ12.7	φ15.9
	Drain	VP25 (External Dia, 32/Internal Dia, 25)				
Panel (Option)	Model	BYK45FJW1		BYK71FJW1		
	Colour	White (10Y9/0.5)				
	Dimensions(HxWxD)	mm	70x1,240x800	70x1,240x800	70x1,240x800	70x1,440x800
	Weight	kg	8.5	8.5	8.5	9.5

Note: Specifications are based on the following conditions:
 • Cooling: Indoor temp.: 27°CDB, 19°CWB, Outdoor temp.: 35°CDB, Equivalent piping length: 7.5 m, Level difference: 0 m.
 • Heating: Indoor temp.: 20°CDB, Outdoor temp.: 7°CDB, 6°CWB, Equivalent piping length: 7.5 m, Level difference: 0 m.
 • Capacity of indoor unit is only for reference. Actual capacity of indoor unit is based on the total capacity index.
 (See Engineering Data Book for details.)
 • Sound level: (FXCQ-M) Anechoic chamber conversion value, measured at a point 1.5 m downward from the unit centre.
 (FXKQ-MA) Anechoic chamber conversion value, measured at a point 1 m in front of the unit and 1 m downward.
 During actual operation, these values are normally somewhat higher as a result of ambient conditions.

Slim Ceiling Mounted Duct Type (700 mm width type)

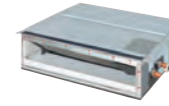

MODEL	with drain pump	FXDQ20PBVE	FXDQ25PBVE	FXDQ32PBVE	
	without drain pump	FXDQ20PBVET	FXDQ25PBVET	FXDQ32PBVET	
Power supply		1-phase, 220-240 V/220 V, 50/60 Hz			
Cooling capacity	kcal/h	1,900	2,400	3,100	
	Btu/h	7,500	9,600	12,300	
	kW	2.2	2.8	3.6	
Heating capacity	kcal/h	2,200	2,800	3,400	
	Btu/h	8,500	10,900	13,600	
	kW	2.5	3.2	4.0	
Power consumption (FXDQ-PBVE)*1	Cooling	kW	0.086	0.086	0.089
	Heating	kW	0.067	0.067	0.070
Power consumption (FXDQ-PBVET)*1	Cooling	kW	0.067	0.067	0.070
	Heating	kW	0.067	0.067	0.070
Casing		Galvanised steel plate			
Airflow rate (HH/H/L)	m ³ /min	8.0/7.2/6.4	8.0/7.2/6.4	8.0/7.2/6.4	
	cfm	282/254/226	282/254/226	282/254/226	
External static pressure	Pa	30-10*2			
Sound level (HH/H/L)*1*3	dB(A)	28/26/23	28/26/23	28/26/24	
Dimensions (HxWxD)	mm	200x700x620	200x700x620	200x700x620	
Machine weight	kg	23.0	23.0	23.0	
Piping connections	Liquid (Flare)	mm	φ6.4	φ6.4	φ6.4
	Gas (Flare)	mm	φ12.7	φ12.7	φ12.7
	Drain	VP20 (External Dia, 26/Internal Dia, 20)			

Slim Ceiling Mounted Duct Type (900/1,100 mm width type)

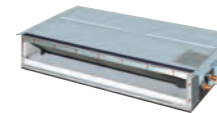

MODEL	with drain pump	FXDQ40NBVE	FXDQ50NBVE	FXDQ63NBVE	
	without drain pump	FXDQ40NBVET	FXDQ50NBVET	FXDQ63NBVET	
Power supply		1-phase, 220-240 V/220 V, 50/60 Hz			
Cooling capacity	kcal/h	3,900	4,800	6,100	
	Btu/h	15,400	19,100	24,200	
	kW	4.5	5.6	7.1	
Heating capacity	kcal/h	4,300	5,400	6,900	
	Btu/h	17,100	21,500	27,300	
	kW	5.0	6.3	8.0	
Power consumption (FXDQ-PBVE)*1	Cooling	kW	0.160	0.165	0.181
	Heating	kW	0.147	0.152	0.168
Power consumption (FXDQ-PBVET)*1	Cooling	kW	0.147	0.152	0.168
	Heating	kW	0.147	0.152	0.168
Casing		Galvanised steel plate			
Airflow rate (HH/H/L)	m ³ /min	10.5/9.5/8.5	12.5/11.0/10.0	16.5/14.5/13.0	
	cfm	371/335/300	441/388/353	583/512/459	
External static pressure	Pa	44-15*2			
Sound level (HH/H/L)*1*3	dB(A)	30/28/26	33/30/27	33/31/29	
Dimensions (HxWxD)	mm	200x900x620	200x900x620	200x1,100x620	
Machine weight	kg	27.0	28.0	31.0	
Piping connections	Liquid (Flare)	mm	φ6.4	φ6.4	φ9.5
	Gas (Flare)	mm	φ12.7	φ12.7	φ15.9
	Drain	VP20 (External Dia, 26/Internal Dia, 20)			

Note: Specifications are based on the following conditions:
 • Cooling: Indoor temp.: 27°CDB, 19°CWB, Outdoor temp.: 35°CDB, Equivalent piping length: 7.5 m, Level difference: 0 m.
 • Heating: Indoor temp.: 20°CDB, Outdoor temp.: 7°CDB, 6°CWB, Equivalent piping length: 7.5 m, Level difference: 0 m.
 • Capacity of indoor unit is only for reference. Actual capacity of indoor unit is based on the total capacity index.
 (See Engineering Data Book for details.)
 • Sound level: Anechoic chamber conversion value, measured at a point 1.5 m downward from the unit centre.
 During actual operation, these values are normally somewhat higher as a result of ambient conditions.
 *1: Values are based on the following conditions: FXDQ-PB: external static pressure of 10 Pa; FXDQ-NB: external static pressure of 15 Pa.
 *2: External static pressure is changeable to set by the remote controller. This pressure means "High static pressure - Standard". (Factory setting is 10 Pa for FXDQ-PB models and 15 Pa for FXDQ-NB models.)
 *3: The values of operation sound level represent those for rear-suction operation. Sound level values for bottom-suction operation can be obtained by adding 5 dB(A).

Specifications

VRV Indoor Units

Middle Static Pressure Ceiling Mounted Duct Type



MODEL		FXSQ20PVE	FXSQ25PVE	FXSQ32PVE	FXSQ40PVE	FXSQ50PVE
Power supply		1-phase, 220-240 V/220 V, 50/60 Hz				
Cooling capacity	kcal/h	1,900	2,400	3,100	3,900	4,800
	Btu/h	7,500	9,600	12,300	15,400	19,100
	kW	2.2	2.8	3.6	4.5	5.6
Heating capacity	kcal/h	2,200	2,800	3,400	4,300	5,400
	Btu/h	8,500	10,900	13,600	17,100	21,500
	kW	2.5	3.2	4.0	5.0	6.3
Power consumption	Cooling	kW 0.058 *1		0.066 *1	0.101 *1	0.075 *1
	Heating	kW 0.053 *1		0.061 *1	0.096 *1	0.070 *1
Casing		Galvanised steel plate				
Airflow rate (H/M/L)	m ³ /min	9/7.5/6.5	9/7.5/6.5	9.5/8/7	15/12.5/10.5	17/14.5/11.5
	cfm	318/265/230	318/265/230	335/282/247	530/441/371	600/512/406
External static pressure	Pa	30-150 (50)*2				50-150 (50)*2
Sound level (H/M/L)	dB(A)	33/30/28		34/32/30	36/33/30	34/32/29
Dimensions (HxWxD)	mm	245x550x800		245x700x800	245x1,000x800	
Machine weight	kg	25		27	35	
Piping connections	Liquid (Flare)	φ 6.4				
	Gas (Flare)	φ 12.7				
	Drain	VP25 (External Dia, 32/Internal Dia, 25)				

MODEL		FXSQ63PVE	FXSQ80PVE	FXSQ100PVE	FXSQ125PVE	FXSQ140PVE
Power supply		1-phase, 220-240 V/220 V, 50/60 Hz				
Cooling capacity	kcal/h	6,100	7,700	9,600	12,000	13,800
	Btu/h	24,200	30,700	38,200	47,800	54,600
	kW	7.1	9.0	11.2	14.0	16.0
Heating capacity	kcal/h	6,900	8,600	10,800	13,800	15,500
	Btu/h	27,300	34,100	42,700	54,600	61,400
	kW	8.0	10.0	12.5	16.0	18.0
Power consumption	Cooling	kW 0.106 *1	0.126 *1	0.151 *1	0.206 *1	0.222 *1
	Heating	kW 0.101 *1	0.121 *1	0.146 *1	0.201 *1	0.217 *1
Casing		Galvanised steel plate				
Airflow rate (H/M/L)	m ³ /min	21/17.5/14.5	23/19.5/16	32/27/22.5	37/31.5/26	39/33.5/28
	cfm	741/618/512	812/688/565	1,130/953/794	1,306/1,112/918	1,377/1,183/988
External static pressure	Pa	50-150 (50)*2				50-140 (50)*2
Sound level (H/M/L)	dB(A)	36/32/29	37.5/34/30	39/35/32	42/38.5/35	43/40/36
Dimensions (HxWxD)	mm	245x1,000x800		245x1,400x800	245x1,550x800	
Machine weight	kg	35	37	46	47	52
Piping connections	Liquid (Flare)	φ 9.5				
	Gas (Flare)	φ 15.9				
	Drain	VP25 (External Dia, 32/Internal Dia, 25)				

Note: Specifications are based on the following conditions;
 •Cooling: Indoor temp.: 27°CDB, 19°CWB, Outdoor temp.: 35°CDB, Equivalent piping length: 7.5 m, Level difference: 0 m.
 •Heating: Indoor temp.: 20°CDB, Outdoor temp.: 7°CDB, 6°CDB, Equivalent piping length: 7.5 m, Level difference: 0 m.
 •Capacity of indoor unit is only for reference. Actual capacity of indoor unit is based on the total capacity index.
 (See Engineering Data Book for details.)
 •Sound level: Anechoic chamber conversion value, measured at a point 1.5 m downward from the unit centre.
 During actual operation, these values are normally somewhat higher as a result of ambient conditions.
 *1: Power consumption values are based on conditions of rated external static pressure.
 *2: External static pressure can be modified using a remote controller that offers thirteen (FXSQ20-40P), eleven (FXSQ50-125P) or ten (FXSQ140P) levels of control. These values indicate the lowest and highest possible static pressures. The rated static pressure is 50 Pa.

Ceiling Mounted Duct Type



MODEL		FXMQ20PVE	FXMQ25PVE	FXMQ32PVE	FXMQ40PVE	FXMQ50PVE
Power supply		1-phase, 220-240 V/220 V, 50/60 Hz				
Cooling capacity	kcal/h	1,900	2,400	3,100	3,900	4,800
	Btu/h	7,500	9,600	12,300	15,400	19,100
	kW	2.2	2.8	3.6	4.5	5.6
Heating capacity	kcal/h	2,200	2,800	3,400	4,300	5,400
	Btu/h	8,500	10,900	13,600	17,100	21,500
	kW	2.5	3.2	4.0	5.0	6.3
Power consumption	Cooling	kW 0.056 *1	0.056 *1	0.060 *1	0.151 *1	0.128 *1
	Heating	kW 0.044 *1	0.044 *1	0.048 *1	0.139 *1	0.116 *1
Casing		Galvanised steel plate				
Airflow rate (HH/H/L)	m ³ /min	9/7.5/6.5	9/7.5/6.5	9.5/8/7	16/13/11	18/16.5/15
	cfm	318/265/230	318/265/230	335/282/247	565/459/388	635/582/530
External static pressure	Pa	30-100 (50)*2	30-100 (50)*2	30-100 (50)*2	30-160 (100)*2	50-200 (100)*2
Sound level (HH/H/L)	dB(A)	33/31/29	33/31/29	34/32/30	39/37/35	41/39/37
Dimensions (HxWxD)	mm	300x550x700	300x550x700	300x550x700	300x700x700	300x1,000x700
Machine weight	kg	25	25	25	28	36
Piping connections	Liquid (Flare)	φ 6.4		φ 6.4	φ 6.4	φ 6.4
	Gas (Flare)	φ 12.7		φ 12.7	φ 12.7	φ 12.7
	Drain	VP25 (External Dia, 32/Internal Dia, 25)				

MODEL		FXMQ63PVE	FXMQ80PVE	FXMQ100PVE	FXMQ125PVE	FXMQ140PVE
Power supply		1-phase, 220-240 V/220 V, 50/60 Hz				
Cooling capacity	kcal/h	6,100	7,700	9,600	12,000	13,800
	Btu/h	24,200	30,700	38,200	47,800	54,600
	kW	7.1	9.0	11.2	14.0	16.0
Heating capacity	kcal/h	6,900	8,600	10,800	13,800	15,500
	Btu/h	27,300	34,100	42,700	54,600	61,400
	kW	8.0	10.0	12.5	16.0	18.0
Power consumption	Cooling	kW 0.138 *1	0.185 *1	0.215 *1	0.284 *1	0.405 *1
	Heating	kW 0.127 *1	0.173 *1	0.203 *1	0.272 *1	0.380 *1
Casing		Galvanised steel plate				
Airflow rate (HH/H/L)	m ³ /min	19.5/17.5/16	25/22.5/20	32/27/23	39/33/28	46/39/32
	cfm	688/618/565	883/794/706	1,130/953/812	1,377/1,165/988	1,624/1,377/1,130
External static pressure	Pa	50-200 (100)*2	50-200 (100)*2	50-200 (100)*2	50-200 (100)*2	50-140 (100)*2
Sound level (HH/H/L)	dB(A)	42/40/38	43/41/39	43/41/39	44/42/40	46/45/43
Dimensions (HxWxD)	mm	300x1,000x700	300x1,000x700	300x1,400x700	300x1,400x700	300x1,400x700
Machine weight	kg	36	36	46	46	47
Piping connections	Liquid (Flare)	φ 9.5		φ 9.5	φ 9.5	φ 9.5
	Gas (Flare)	φ 15.9		φ 15.9	φ 15.9	φ 15.9
	Drain	VP25 (External Dia, 32/Internal Dia, 25)				

Note: Specifications are based on the following conditions;
 •Cooling: Indoor temp.: 27°CDB, 19°CWB, Outdoor temp.: 35°CDB, Equivalent piping length: 7.5 m, Level difference: 0 m.
 •Heating: Indoor temp.: 20°CDB, Outdoor temp.: 7°CDB, 6°CDB, Equivalent piping length: 7.5 m, Level difference: 0 m.
 •Capacity of indoor unit is only for reference. Actual capacity of indoor unit is based on the total capacity index.
 (See Engineering Data Book for details.)
 •Sound level: Anechoic chamber conversion value, measured at a point 1.5 m downward from the unit centre.
 During actual operation, these values are normally somewhat higher as a result of ambient conditions.
 *1: Power consumption values are based on conditions of rated external static pressure.
 *2: External static pressure can be modified using a remote controller that offers seven (FXMQ20-32P), thirteen (FXMQ40P), fourteen (FXMQ50-125P) or ten (FXMQ140P) levels of control. These values indicate the lowest and highest possible static pressures. The standard static pressure is 50 Pa for FXMQ20-32P and 100 Pa for FXMQ40-140P.

Specifications

VRV Indoor Units

Ceiling Mounted Duct Type



MODEL		FXMQ200MAVE	FXMQ250MAVE
Power supply		1-phase, 220-240 V/220 V, 50/60 Hz	
Cooling capacity	kcal/h	19,300	24,100
	Btu/h	76,400	95,500
	kW	22.4	28.0
Heating capacity	kcal/h	21,500	27,100
	Btu/h	85,300	107,500
	kW	25.0	31.5
Power consumption	Cooling kW	1.294 *1	1.465 *1
	Heating kW	1.294 *1	1.465 *1
Casing		Galvanised steel plate	
Airflow rate (H/L)	m ³ /min	58/50	72/62
	cfm	2,047/1,765	2,542/2,189
External static pressure	Pa	132-221 *2	191-270 *2
Sound level(H/L)	220 V	48/45	48/45
	240 V	49/46	49/46
Dimensions (HxWxD)	mm	470x1,380x1,100	470x1,380x1,100
Machine weight	kg	137	137
Piping connections	Liquid (Flare)	φ 9.5	φ 9.5
	Gas (Brazing)	φ 19.1	φ 22.2
	Drain		
PS1B			

Ceiling Suspended Type



MODEL		FXHQ32MAVE	FXHQ63MAVE	FXHQ100MAVE
Power supply		1-phase, 220-240 V/220 V, 50/60 Hz		
Cooling capacity	kcal/h	3,100	6,100	9,600
	Btu/h	12,300	24,200	38,200
	kW	3.6	7.1	11.2
Heating capacity	kcal/h	3,400	6,900	10,800
	Btu/h	13,600	27,300	42,700
	kW	4.0	8.0	12.5
Power consumption	Cooling kW	0.111	0.115	0.135
	Heating kW	0.111	0.115	0.135
Casing		White (10Y9/0.5)		
Airflow rate (H/L)	m ³ /min	12/10	17.5/14	25/19.5
	cfm	424/353	618/494	883/688
Sound level (H/L)	dB(A)	36/31	39/34	45/37
Dimensions (HxWxD)	mm	195x960x680	195x1,160x680	195x1,400x680
Machine weight	kg	24.0	28.0	33.0
Piping connections	Liquid (Flare)	φ 6.4	φ 9.5	φ 9.5
	Gas (Flare)	φ 12.7	φ 15.9	φ 15.9
	Drain			
VP20 (External Dia, 26/Internal Dia, 20)				

Note: Specifications are based on the following conditions:

- Cooling: Indoor temp.: 27°CDB, 19°CWB, Outdoor temp.: 35°CDB, Equivalent piping length: 7.5 m, Level difference: 0 m.
- Heating: Indoor temp.: 20°CDB, Outdoor temp.: 7°CDB, 6°CDB, Equivalent piping length: 7.5 m, Level difference: 0 m.
- Capacity of indoor unit is only for reference. Actual capacity of indoor unit is based on the total capacity index. (See Engineering Data Book for details.)
- Sound level: (FXMQ-MA) Anechoic chamber conversion value, measured at a point 1.5 m downward from the unit centre. (FXHQ-MA) Anechoic chamber conversion value, measured at a point 1 m in front of the unit and 1 m downward. During actual operation, these values are normally somewhat higher as a result of ambient conditions.
- *1: Power consumption values are based on conditions of standard external static pressure.
- *2: External static pressure is changeable to change over the connectors inside electrical box, this pressure means "Standard-High static pressure".

Wall Mounted Type



MODEL		FXAQ20PVE	FXAQ25PVE	FXAQ32PVE	FXAQ40PVE	FXAQ50PVE	FXAQ63PVE
Power supply		1-phase, 220-240 V/220 V, 50/60 Hz					
Cooling capacity	kcal/h	1,900	2,400	3,100	3,900	4,800	6,100
	Btu/h	7,500	9,600	12,300	15,400	19,100	24,200
	kW	2.2	2.8	3.6	4.5	5.6	7.1
Heating capacity	kcal/h	2,200	2,800	3,400	4,300	5,400	6,900
	Btu/h	8,500	10,900	13,600	17,100	21,500	27,300
	kW	2.5	3.2	4.0	5.0	6.3	8.0
Power consumption	Cooling kW	0.019	0.028	0.030	0.020	0.033	0.050
	Heating kW	0.029	0.034	0.035	0.020	0.039	0.060
Casing		White (3.0Y8.5/0.5)					
Airflow rate (H/L)	m ³ /min	7.5/4.5	8/5	8.5/5.5	12/9	15/12	19/14
	cfm	265/159	282/177	300/194	424/318	530/424	671/494
Sound level (H/L)	dB(A)	35/31	36/31	38/31	39/34	42/37	47/41
Dimensions (HxWxD)	mm	290x795x238	290x795x238	290x795x238	290x1,050x238	290x1,050x238	290x1,050x238
Machine weight	kg	11.0	11.0	11.0	14.0	14.0	14.0
Piping connections	Liquid (Flare)	φ 6.4	φ 6.4	φ 6.4	φ 6.4	φ 6.4	φ 9.5
	Gas (Flare)	φ 12.7	φ 12.7	φ 12.7	φ 12.7	φ 12.7	φ 15.9
	Drain						
VP13 (External Dia, 18/Internal Dia, 13)							

Floor Standing Type/Concealed Floor Standing Type

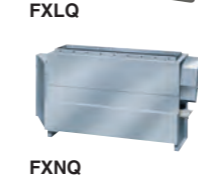

MODEL		FXLQ20MAVE	FXLQ25MAVE	FXLQ32MAVE	FXLQ40MAVE	FXLQ50MAVE	FXLQ63MAVE
		FXNQ20MAVE	FXNQ25MAVE	FXNQ32MAVE	FXNQ40MAVE	FXNQ50MAVE	FXNQ63MAVE
Power supply		1-phase, 220-240 V/220 V, 50/60 Hz					
Cooling capacity	kcal/h	1,900	2,400	3,100	3,900	4,800	6,100
	Btu/h	7,500	9,600	12,300	15,400	19,100	24,200
	kW	2.2	2.8	3.6	4.5	5.6	7.1
Heating capacity	kcal/h	2,200	2,800	3,400	4,300	5,400	6,900
	Btu/h	8,500	10,900	13,600	17,100	21,500	27,300
	kW	2.5	3.2	4.0	5.0	6.3	8.0
Power consumption	Cooling kW	0.049	0.049	0.090	0.090	0.110	0.110
	Heating kW	0.049	0.049	0.090	0.090	0.110	0.110
Casing		FXLQ: Ivory white (5Y7.5/1)/FXNQ: Galvanised steel plate					
Airflow rate (H/L)	m ³ /min	7/6	7/6	8/6	11/8.5	14/11	16/12
	cfm	247/212	247/212	282/212	388/300	494/388	565/424
Sound level (H/L)	220 V	35/32	35/32	35/32	38/33	39/34	40/35
	240 V	37/34	37/34	37/34	40/35	41/36	42/37
Dimensions (HxWxD)	FXLQ	600x1,000x222	600x1,000x222	600x1,140x222	600x1,140x222	600x1,420x222	600x1,420x222
	FXNQ	610x930x220	610x930x220	610x1,070x220	610x1,070x220	610x1,350x220	610x1,350x220
Machine weight	FXLQ	25.0	25.0	30.0	30.0	36.0	36.0
	FXNQ	19.0	19.0	23.0	23.0	27.0	27.0
Piping connections	Liquid (Flare)	φ 6.4	φ 6.4	φ 6.4	φ 6.4	φ 6.4	φ 9.5
	Gas (Flare)	φ 12.7	φ 12.7	φ 12.7	φ 12.7	φ 12.7	φ 15.9
	Drain						
210.D.							

Note: Specifications are based on the following conditions:

- Cooling: Indoor temp.: 27°CDB, 19°CWB, Outdoor temp.: 35°CDB, Equivalent piping length: 7.5 m, Level difference: 0 m.
- Heating: Indoor temp.: 20°CDB, Outdoor temp.: 7°CDB, 6°CDB, Equivalent piping length: 7.5 m, Level difference: 0 m.
- Capacity of indoor unit is only for reference. Actual capacity of indoor unit is based on the total capacity index. (See Engineering Data Book for details.)
- Sound level: (FXAQ-P) Anechoic chamber conversion value, measured at a point 1 m in front of the unit and 1 m downward. (FXLQ-MA, FXNQ-MA) Anechoic chamber conversion value, measured at a point 1.5 m in front of the unit at a height of 1.5 m. During actual operation, these values are normally somewhat higher as a result of ambient conditions.

Specifications

Residential Indoor Units with Connection to BP Units

Slim Ceiling Mounted Duct Type

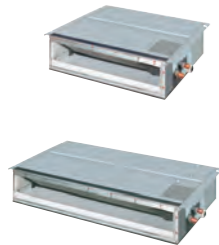

MODEL		CDXS25EAVMA	CDXS35EAVMA	FDXS25CVMA	FDXS35CVMA	FDXS50CVMA	FDXS60CVMA
Power supply		1-phase, 220-240 V/220-230 V, 50/60 Hz					
Airflow rates (H)	m ³ /min (cfm)	8.7 (307)	9.5 (335)	10.0 (353)	12.0 (424)	16.0 (565)	
Sound levels (H/L/SL)*	dB (A)	35/31/29		37/33/31		38/34/32	
Fan speed		5 steps, quiet and automatic					
Temperature control		Microcomputer control					
Dimensions (H×W×D)	mm	200×700×620		200×900×620		200×1,100×620	
Machine weight	kg	21		25	27	30	
Piping connections	Liquid (Flare)	φ6.4					
	Gas (Flare)	φ9.5					
	Drain	VP20 (External Dia. 26/Internal Dia. 20)					
Heat insulation		Both liquid and gas pipes					
External static pressure	Pa	30		40			

Note: * The operation sound level values represent those for rear-suction operation and an external static pressure of 30 Pa for CDXS-EA and 40 Pa for FDXS-C. Sound level values for bottom-suction operation can be obtained by adding 6 dB (A) for CDXS-EA and 5 dB (A) for FDXS-C.

Wall Mounted Type



MODEL		FTXS20DVMA	FTXS25EVMA	FTXS35EVMA	FTXS50FVMA	FTXS60FVMA	FTXS71FVMA
Power supply		1-phase, 220-240 V/220-230 V, 50/60 Hz					
Front panel colour		White					
Airflow rates (H)	Cooling	8.7 (307)	8.9 (314)	14.7 (519)	16.2 (572)	17.4 (614)	
	Heating	9.4 (332)	9.7 (342)	16.2 (572)	17.4 (614)	21.5 (759)	
Sound levels (H/L/SL)	Cooling	37/25/22	39/26/23	43/34/31	45/36/33	46/37/34	
	Heating	37/28/25	38/29/26	42/33/30	44/35/32	46/37/34	
Fan speed		5 steps, quiet and automatic					
Temperature control		Microcomputer control					
Dimensions (H×W×D)	mm	283×800×195			290×1,050×238		
Machine weight	kg	9			12		
Piping connections	Liquid (Flare)	φ6.4					
	Gas (Flare)	φ9.5		φ12.7		φ15.9	
	Drain	φ18.0					
Heat insulation		Both liquid and gas pipes					

BP Units for connection to residential indoor units



MODEL		BPMKS967A3	BPMKS967A2		
Power supply		1-phase, 220-240 V/220-230 V, 50/60 Hz			
Number of ports		3 (connectable to 1-3 indoor units)	2 (connectable to 1-2 indoor units)		
Power consumption		W			
Running current		A			
Dimensions (H×W×D)		mm			
Machine weight		kg	kg		
Number of wiring connections		3 for power supply (including earth wiring), 2 for interunit wiring (outdoor unit-BP, BP-BP), 4 for interunit wiring (BP-indoor unit)			
Piping connections (Brazing)	Liquid	Main	mm	φ9.5×1	
		Branch	mm	φ6.4×3	φ6.4×2
	Gas	Main	mm	φ19.1×1	
		Branch	mm	φ15.9×3	φ15.9×2
Heat insulation		Both liquid and gas pipes			
Connectable indoor units		2.0 kW class to 7.1 kW class residential indoor units			
Min. rated capacity of connectable indoor units		kW			
Max. rated capacity of connectable indoor units		kW		20.8	14.2

Note: * Total auxiliary piping length.

Specifications

Outdoor Units

VRV IV S SERIES

Heat Pump



MODEL		RXYMQ3AVE	RXYMQ4AVE	RXYMQ5AVE	RXYMQ6AVE	RXYMQ8AY1	RXYMQ9AY1
Power supply		1-phase, 220-230 V/220 V, 50/60 Hz				3-phase, 380-415 V, 50 Hz	
Cooling capacity	kcal/h	7,740	9,600	12,000	13,800	19,300	20,600
	Btu/h	30,700	38,200	47,800	54,600	76,400	81,900
	kW	9.0	11.2	14.0	16.0	22.4	24.0
Heating capacity	kcal/h	8,600	10,800	12,000	15,500	21,500	22,400
	Btu/h	34,100	42,700	47,800	61,400	85,300	88,700
	kW	10.0	12.5	14.0	18.0	25.0	26.0
Power consumption	Cooling	2.44	2.88	3.93	4.14	5.94	6.88
	Heating	2.28	2.60	3.04	4.07	6.25	6.82
Capacity control	%	24 to 100		16 to 100		20 to 100	
Casing colour		Ivory white (5Y7.5/1)					
Compressor	Type	Hermetically sealed swing type				Hermetically sealed scroll type	
	Motor output	kW	1.92	3.0	3.5	3.8	4.8
Airflow rate	m ³ /min	76			106	140	
Dimensions (HxWxD)	mm	990x940x320			1,345x900x320	1,430x940x320	
Machine weight	kg	71	82	104	138		
Sound level (Cooling/Heating)	dB(A)	51/52	52/54	53/54	55/56	57/58	58/59
Operation range	Cooling	°CDB	-5 to 46				
	Heating	°CWB	-20 to 15.5				
Refrigerant	Type	R-410A					
	Charge	kg	2.9	3.4	3.6	5.8	
Piping connections	Liquid	φ9.5 (Flare)				φ9.5 (Brazing)	
	Gas	φ15.9 (Flare)			φ19.1 (Flare)	φ 19.1 (Brazing)	φ 22.2 (Brazing)

Note: Specifications are based on the following conditions:

- Cooling: Indoor temp.: 27°CDB, 19°CWB, Outdoor temp.: 35°CDB, Equivalent piping length: 7.5 m, Level difference: 0 m.
 - Heating: Indoor temp.: 20°CDB, Outdoor temp.: 7°CDB, 6°CWB, Equivalent piping length: 7.5 m, Level difference: 0 m.
 - Sound level: Anechoic chamber conversion value, measured at a point 1 m in front of the unit at a height of 1.5 m.
- During actual operation, these values are normally somewhat higher as a result of ambient conditions.
- Refrigerant charge is required.

Outdoor unit combinations

MODEL	RXYMQ3AVE	RXYMQ4AVE	RXYMQ5AVE	RXYMQ6AVE	RXYMQ8AY1	RXYMQ9AY1	
kW	9.0	11.2	14.0	16.0	22.4	24.0	
HP	3	4	5	6	8	9	
Capacity index	80	100	125	150	200	215	
Total capacity index of connectable indoor units	Combination (%)	50%*1	40	50	62.5	75	100
		80%*2	64	80	100	120	160
		100%	80	100	125	150	200
		130%	104	130	162.5	195	260
Maximum number of connectable indoor units	5	6	8	9	13	14	

Note: *1. When only VRV indoor units are connected, connection ratio must be 50% to 130%.

*2. When a mixed combination of VRV and residential indoor units is connected or when only residential indoor units are connected, connection ratio must be 80% to 130%.

Option List

VRV Indoor Units

Ceiling Mounted Cassette (Round Flow with Sensing) Type

No.	Item	Type	FXFQ25S	FXFQ32S	FXFQ40S	FXFQ50S	FXFQ63S	FXFQ80S	FXFQ100S	FXFQ125S
1	Decoration panel					BYCQ125B-W1				
2	Sealing material of air discharge outlet					KDBHQ55B140				
3	Panel spacer					KDBP55H160FA				
4	Filter related	High efficiency filter unit 65%				KAFP556B80			KAFP556B160	
		High efficiency filter unit 90%				KAFP557B80			KAFP557B160	
		Replacement high efficiency filter 65%				KAFP552B80			KAFP552B160	
		Replacement high efficiency filter 90%				KAFP553B80			KAFP553B160	
		Filter chamber				KDDFP55B160				
		Long life replacement filter				KAFP551K160				
		Ultra long-life filter				KAFP55B160				
5	Fresh air intake kit	Replacement ultra long-life filter				KAFP55H160H				
		Chamber type	Without T joint-pipe and fan			KDDQ55B140				
		With T joint-pipe without fan			KDDP55B160K					
6	Branch duct chamber	Direct installation type				KDDP55X160				
						KDJP55B80			KDJP55B160	
7	Insulation kit for high humidity					KDTP55K80			KDTP55K160	

Ceiling Mounted Cassette (Round Flow) Type

No.	Item	Type	FXFQ25LU	FXFQ32LU	FXFQ40LU	FXFQ50LU	FXFQ63LU	FXFQ80LU	FXFQ100LU	FXFQ125LU
1	Decoration panel					BYCP125K-W1				
2	Sealing material of air discharge outlet					KDBH55K160F				
3	Panel spacer					KDBP55H160FA				
4	Filter related	High efficiency filter unit 65%				KAFP556B80			KAFP556B160	
		High efficiency filter unit 90%				KAFP557B80			KAFP557B160	
		Replacement high efficiency filter 65%				KAFP552B80			KAFP552B160	
		Replacement high efficiency filter 90%				KAFP553B80			KAFP553B160	
		Filter chamber				KDDFP55B160				
		Long life replacement filter				KAFP551K160				
		Ultra long-life filter				KAFP55B160				
5	Fresh air intake kit	Replacement ultra long-life filter				KAFP55H160H				
		Chamber type	Without T joint-pipe and fan			KDDP55B160				
		With T joint-pipe without fan			KDDP55B160K					
6	Branch duct chamber	Direct installation type				KDDP55X160				
						KDJP55B80			KDJP55B160	
7	Chamber connection kit					KKSJ55KA160				
8	Insulation kit for high humidity					KDTP55K80			KDTP55K160	

Ceiling Mounted Cassette (Compact Multi Flow) Type

No.	Item	Type	FXZQ20M	FXZQ25M	FXZQ32M	FXZQ40M	FXZQ50M
1	Decoration panel				BYFQ60B3W1		
2	Sealing material of air discharge outlet				KDBH44BA60		
3	Panel spacer				KDBQ44BA60A		
4	Replacement long-life filter				KAFQ441BA60		
5	Fresh air intake kit	Direct installation type			KDDQ44XA60		

4-Way Flow Ceiling Suspended Type

No.	Item	Type	FXUQ71A	FXUQ100A
1	Sealing material of air discharge outlet			KDBHP49B140
2	Decoration panel for air discharge			KDBTP49B140
3	Replacement long-life filter			KAFP551K160

Ceiling Mounted Cassette (Double Flow) Type

No.	Item	Type	FXCQ20M FXCQ25M FXCQ32M	FXCQ40M	FXCQ50M	FXCQ63M	FXCQ80M	FXCQ125M
1	Decoration panel		BYBC32G-W1	BYBC50G-W1	BYBC63G-W1	BYBC125G-W1		
2	Filter related	High efficiency filter 65% *1	KAFJ532G36	KAFJ532G56	KAFJ532G80	KAFJ532G160		
		High efficiency filter 90% *1	KAFJ533G36	KAFJ533G56	KAFJ533G80	KAFJ533G160		
		Filter chamber bottom suction	KDDFJ53G36	KDDFJ53G56	KDDFJ53G80	KDDFJ53G160		
		Long life replacement filter	KAFJ531G36	KAFJ531G56	KAFJ531G80	KAFJ531G160		

Note: *1 Filter chamber is required if installing high efficiency filter.

Ceiling Mounted Cassette Corner Type

No.	Item	Type	FXKQ25MA	FXKQ32MA	FXKQ40MA	FXKQ63MA
1	Panel related	Decoration panel		BYK45FJW1		BYK71FJW1
		Panel spacer		KPBJS2F56W		KPBJS2F80W
2	Air inlet and air discharge outlet related	Long life replacement filter		KAFJ521F56		KAFJ521F80
		Air discharge grille		K-HV7AW		K-HV9AW
		Air discharge blind panel		KDBJS2F56W		KDBJS2F80W
		Flexible duct (with shutter)		KFDJ52FA56		KFDJ52FA80

Slim Ceiling Mounted Duct Type

No.	Item	Type	FXDQ20PB	FXDQ25PB	FXDQ32PB	FXDQ40NB	FXDQ50NB	FXDQ63NB
1	Insulation kit for high humidity			KDT25N32		KDT25N50		KDT25N63

Middle Static Pressure Ceiling Mounted Duct Type

No.	Item	Type	FXSQ20P FXSQ25P FXSQ32P	FXSQ40P	FXSQ50P FXSQ63P FXSQ80P	FXSQ100P FXSQ125P	FXSQ140P
1	High efficiency filter *1	65%	KAFP632B36	KAFP632B56	KAFP632B80	KAFP632B160	KAFP632B160B
		90%	KAFP633B36	KAFP633B56	KAFP633B80	KAFP633B160	KAFP633B160B
2	Filter chamber (for rear suction) *1		KDDFP63B36	KDDFP63B56	KDDFP63B80	KDDFP63B160	KDDFP63B160B
3	Long-life filter *1		KAFP631B36	KAFP631B56	KAFP631B80	KAFP631B160	KAFP631B160B
4	Service panel	White	KTBJ25K36W	KTBJ25K56W	KTBJ25K80W	KTBJ25K160W	
		Fresh white	KTBJ25K36F	KTBJ25K56F	KTBJ25K80F	KTBJ25K160F	
		Brown	KTBJ25K36T	KTBJ25K56T	KTBJ25K80T	KTBJ25K160T	
5	Air discharge adaptor		KDAP25A36A	KDAP25A56A	KDAP25A71A	KDAP25A140A	KDAP25A160A *2
6	Shield plate for side plate				KDDB63A160		-

Note: *1. If installing high efficiency filter and long-life filter to the unit, filter chamber is required.

*2. This option is a set of KDAP25A140A and KDBHP37A160.

Ceiling Mounted Duct Type

No.	Item	Type	FXMQ20P FXMQ25P FXMQ32P	FXMQ40P	FXMQ50P FXMQ63P FXMQ80P	FXMQ100P FXMQ125P FXMQ140P	FXMQ200MA FXMQ250MA
1	Drain pump kit						KDU30L250VE
2	High efficiency filter	65%	KAF372AA36	KAF372AA56	KAF372AA80	KAF372AA160	KAFJ372L280
		90%	KAF373AA36	KAF373AA56	KAF373AA80	KAF373AA160	KAFJ373L280
3	Filter chamber		KDDF37AA36	KDDF37AA56	KDDF37AA80	KDDF37AA160	KDJ3705L280
4	Long life replacement filter		KAF371AA36	KAF371AA56	KAF371AA80	KAF371AA160	KAFJ371L280
5	Long life filter chamber kit		KAF375AA36	KAF375AA56	KAF375AA80	KAF375AA160	
6	Service panel	White	KTBJ25K36W	KTBJ25K56W	KTBJ25K80W	KTBJ25K160W	
		Fresh white	KTBJ25K36F	KTBJ25K56F	KTBJ25K80F	KTBJ25K160F	
		Brown	KTBJ25K36T	KTBJ25K56T	KTBJ25K80T	KTBJ25K160T	
7	Air discharge adaptor		KDAJ25K36A	KDAJ25K56A	KDAJ25K71A	KDAJ25K140A	

Ceiling Suspended Type

No.	Item	Type	FXHQ32MA	FXHQ63MA	FXHQ100MA
1	Drain pump kit		KDU50N60VE		KDU50N125VE
2	Replacement long-life filter (Resin net)		KAF501DA56	KAF501DA80	KAF501DA112
3	L-type piping kit (for upward direction)		KHFP5MA63		KHFP5MA160

Wall Mounted Type

No.	Item	Type	FXAQ20P	FXAQ25P	FXAQ32P	FXAQ40P	FXAQ50P	FXAQ63P
1	Drain pump kit							K-KDU572EVE

Floor Standing Type

No.	Item	Type	FXLQ20MA	FXLQ25MA	FXLQ32MA	FXLQ40MA	FXLQ50MA	FXLQ63MA
1	Long life replacement filter		KAFJ361K28		KAFJ361K45			KAFJ361K71

Concealed Floor Standing Type

No.	Item	Type	FXNQ20MA	FXNQ25MA	FXNQ32MA	FXNQ40MA	FXNQ50MA	FXNQ63MA
1	Long life replacement filter		KAFJ361K28		KAFJ361K45			KAFJ361K71

Option List

Residential Indoor Units with Connection to BP Units

Slim Ceiling Mounted Duct Type

No.	Item	Type	CDXS25EAVMA	CDXS35EAVMA	FDXS25CVMA	FDXS35CVMA	FDXS50CVMA	FDXS60CVMA
1	Insulation kit for high humidity		KDT25N32		KDT25N50			KDT25N63

BP Units for connection to residential indoor units

No.	Item	Type	BPMKS967A2	BPMKS967A3
1	REFNET joint		KHRP26A22T	

Note: A single BP unit does not require a REFNET joint. 2 BP units require only 1 REFNET joint, and 3 BP units require only 2 REFNET joints.

Outdoor Units

No.	Item	Type	RXYMQ3AVE	RXYMQ4AVE	RXYMQ5AVE	RXYMQ6AVE	RXYMQ8AY1	RXYMQ9AY1	
1	Cool/Heat selector		KRC19-26A						
1-1	Fixing box		KJB111A						
2	REFNET header		KHRP26M22H (Max. 4 branch)						
			KHRP26M33H (Max. 8 branch)						
3	REFNET joint		KHRP26A22T					KHRP26A22T, KHRP26A33T	
4	Central drain plug		KKPJ5G280			KKPJ5F180	KKPJ5G280		
5	Fixture for preventing overturning		KKTP5B112			KPT-60B160	KKTP5B112		
6	Wire fixture for preventing overturning		-					K-KYZP15C	

Option List

Control Systems

Operation Control System Optional Accessories

For VRF indoor unit use

No.	Item	Type	FXFQ-S	FXFQ-LU	FXZQ-M	FXUQ-A	FXCQ-M	FXKQ-MA	FXDQ-PB FXDQ-NB
1	Remote controller	Wireless	BRC7F634F	BRC7E530W	BRC7CB58	BRC4C62	BRC4C61	BRC4C65	
		Wired	BRC1C62						
2	Navigation remote controller (Wired remote controller)		BRC1E62 Note 7						
3	Simplified remote controller (Exposed type)		—						
4	Remote controller for hotel use (Concealed type)		—						
5	Adaptor for wiring		★KRP1C63	★KRP1BA57	—	★KRP1B61	KRP1B61	★KRP1B56	
6-1	Wiring adaptor for electrical appendices (1)		★KRP2A62	★KRP2A62	—	★KRP2A61	KRP2A61	★KRP2A53	
6-2	Wiring adaptor for electrical appendices (2)		★KRP4AA53	★KRP4AA53	★KRP4AA53	★KRP4AA51	KRP4AA51	★KRP4A54	
7	Remote sensor (for indoor temperature)		KRCS01-4B	KRCS01-1B	KRCS01-4B	KRCS01-1B			
8	Installation box for adaptor PCB☆		Note 2, 3 KRP1H98	Note 4, 6 KRP1BA101	KRP1BA97	Note 2, 3 KRP1B96	—	Note 4, 6 KRP1BA101	
9	External control adaptor for outdoor unit		★DTA104A62	★DTA104A62	—	★DTA104A61	DTA104A61	★DTA104A53	
10	Adaptor for multi tenant		★DTA114A61	—					

No.	Item	Type	FXSQ-P	FXMQ-P	FXMQ-MA	FXHQ-MA	FXAQ-P	FXLQ-MA FXNQ-MA
1	Remote controller	Wireless	BRC4C65	BRC4C62	BRC7EA63W	BRC7EA618	BRC4C62	
		Wired	BRC1C62					
2	Navigation remote controller (Wired remote controller)		BRC1E62 Note 7					
3	Simplified remote controller (Exposed type)		BRC2C51	BRC2C51	—	—	BRC2C51	
4	Remote controller for hotel use (Concealed type)		BRC3A61	BRC3A61	—	—	BRC3A61	
5	Adaptor for wiring		★KRP1C64	KRP1B61	KRP1BA54	—	KRP1B61	
6-1	Wiring adaptor for electrical appendices (1)		★KRP2A61	KRP2A61	★KRP2A62	★KRP2A61	KRP2A61	
6-2	Wiring adaptor for electrical appendices (2)		★KRP4AA51	KRP4AA51	★KRP4AA52	★KRP4AA51	KRP4AA51	
7	Remote sensor (for indoor temperature)		KRCS01-4B		KRCS01-1B			
8	Installation box for adaptor PCB☆		Note 2, 3 KRP4A98	Note 2, 3 KRP4A96	—	Note 3 KRP1CA93	Note 2, 3 KRP4AA93	—
9	External control adaptor for outdoor unit		★DTA104A61	DTA104A61	★DTA104A62	★DTA104A61	DTA104A61	
10	Adaptor for multi tenant		★DTA114A61	—	—	★DTA114A61	—	

- Note: 1. Installation box☆ is necessary for each adaptor marked ★.
 2. Up to 2 adaptors can be fixed for each installation box.
 3. Only one installation box can be installed for each indoor unit.
 4. Up to 2 installation boxes can be installed for each indoor unit.
 5. Installation box☆ is necessary for second adaptor.
 6. Installation box☆ is necessary for each adaptor.
 7. Individual airflow direction, auto airflow rate and sensing sensor control can be set only via wired remote controller BRC1E62. Cannot be set via other remote controllers.
 Available functions depend on the type of indoor unit.

For residential indoor unit use

No.	Item	Type	CDXS-EA FDXS-C	FTXS-D,E,F
1	Remote controller	Wireless type	— Note 1	
2	Wiring adaptor for time clock/remote controller Note 2 (Normal open pulse contact/normal open contact)		KRP413AB1S	
3	Remote controller loss prevention chain		KKF917A4	KKF917A4
4	Interface adaptor for DIII-NET use		KRP928BB2S	

- Note: 1. A wireless remote controller is a standard accessory.
 2. Time clock and other devices should be obtained locally.

System Configuration

No.	Item	Type	Model No.	Function
1	Residential central remote controller		Note 2 DCS303A51	• Up to 16 groups of indoor units (128 units) can be easily controlled using the large LCD panel. ON/OFF, temperature settings and scheduling can be controlled individually for indoor units.
2	Central remote controller		DCS302CA61	• Up to 64 groups of indoor units (128 units) can be connected, and ON/OFF, temperature setting and monitoring can be accomplished individually or simultaneously. Connectable up to 2 controllers in one system.
2-1	Electrical box with earth terminal (3 blocks)		KJB311AA	
3	Unified ON/OFF controller		DCS301BA61	• Up to 16 groups of indoor units (128 units) can be turned, ON/OFF individually or simultaneously, and operation and malfunction can be displayed. Can be used in combination with up to 8 controllers.
3-1	Electrical box with earth terminal (2 blocks)		KJB212AA	
3-2	Noise filter (for electromagnetic interface use only)		KEK26-1A	
4	Schedule timer		DST301BA61	• Programmed time weekly schedule can be controlled by unified control for up to 64 groups of indoor units (128 units). Can turn units ON/OFF twice per day.
5	5-room centralised controller for residential indoor units	For C(F)DXS, FTXS	Note 3 KRC72A	• Up to 5 indoor units can be controlled. This is a low cost system which can only control ON/OFF.
6	Interface adaptor for residential indoor units		KRP928BB2S	• Adaptors required to connect products other than those of the VRF System to the high-speed DIII-NET communication system adopted for the VRF System.
7	Interface adaptor for SkyAir-series		Note 4 ★DTA112BA51	
8	Central control adaptor kit For UAT(Y)-K(A),FD-K		★DTA107A55	
9	Wiring adaptor for other air-conditioner		★DTA103A51	* To use any of the above optional controllers, an appropriate adaptor must be installed on the product unit to be controlled.
10	DIII-NET Expander Adaptor		DTA109A51	• Up to 1024 units can be centrally controlled in 64 different groups. • Wiring restrictions (max. length: 1,000m, total wiring length: 2,000m, max. number of branches: 16) apply to each adaptor.
10-1	Mounting plate		KRP4A92	• Fixing plate for DTA109A51

- Note: 1. Installation box for ★ adaptor must be obtained locally.
 2. For residential use only. Cannot be used with other centralised control equipment.
 3. A wiring adaptor (KRP413AB1S) is also required for each indoor unit.
 4. No adaptor is required for some indoor units.

Building Management System

No.	Item	Type	Model No.	Function
1	intelligent Touch Controller	Basic	DCS601C51	• Air-Conditioning management system that can be controlled by a compact all-in-one unit.
1-1		Option	DCS601A52	• Additional 64 groups (10 outdoor units) is possible.
1-2	Electrical box with earth terminal (4 blocks)		KJB411A	• Wall embedded switch box.
2		Basic	DCM601A51	• Air-conditioning management system that can be controlled by touch screen.
2-1		Hardware	DCM601A52	• Additional 64 groups (10 outdoor units) is possible. Max. 7 iTM plus adaptors can be connected to intelligent Touch Manager.
2-2		Option	DCM002A51	• Power consumption of indoor units are calculated based on operation status of the indoor unit and outdoor unit power consumption measured by kWh metre.
2-3		Software	DCM008A51	• Building energy consumption is visualised. Wasted air-conditioning energy can be found out.
2-4			DCM009A51	• BACnet equipment can be managed by intelligent Touch Manager.
2-5			DCM007A51	• Interface for intelligent Touch Manager by HTTP
2-6	Di unit		DEC101A51	• 8 pairs based on a pair of ON/OFF input and abnormality input.
2-7	Dio unit		DEC102A51	• 4 pairs based on a pair of ON/OFF input and abnormality input.
3		*1 Interface for use in BACnet®	DMS502B51	• Interface unit to allow communications between VRF and BMS. Operation and monitoring of air-conditioning systems through BACnet® communication.
3-1		Optional DIII board	DAM411B51	• Expansion kit, installed on DMS502B51, to provide 2 more DIII-NET communication ports. Not usable independently.
3-2		Optional Di board	DAM412B51	• Expansion kit, installed on DMS502B51, to provide 16 more wattmeter pulse input points. Not usable independently.
4		*2 Interface for use in LONWORKS®	DMS504B51	• Interface unit to allow communications between VRF and BMS. Operation and monitoring of air-conditioning systems through LonWorks® communication.
5		Home Automation Interface Adaptor	DTA116A51	• Use of the Modbus protocol enables the connection of the VRF system with a variety of home automation systems from other manufacturers.
6	Contact/analogue signal	Unification adaptor for computerised control	★DCS302A52	• Interface between the central monitoring board and central control units.

- Note: *1. BACnet® is a registered trademark of American Society of Heating, Refrigerating and Air-Conditioning Engineers (ASHRAE).
 *2. LonWorks® is a trademark of Echelon Corporation registered in the United States and other countries.
 *3. Installation box for ★ adaptor must be obtained locally.

Control Systems

Individual Control Systems for VRV Indoor Units

Navigation remote controller (Wired remote controller) (Option)



BRC1E62

Clear display

- **Dot matrix display**
 - A combination of fine dots enables various icons. Large text display is easy to see.

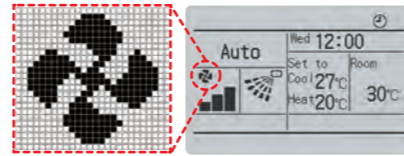

• Backlight display

- Backlight display helps operating in dark rooms.

Simple operation

• Large buttons and arrow keys

- Large buttons and arrow keys enable easy operation. Basic setting such as fan speed and temperature can be intuitively operated. For other settings just select the function from the menu list.

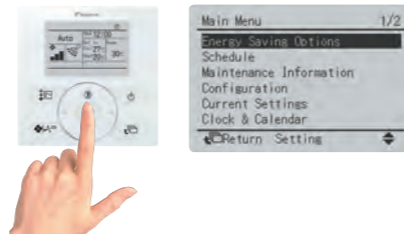

• Guide on display

- The display gives an explanation of each setting for easy operation.

Energy saving

• Auto operation mode

- Until now only the temperature for one point could be set, but now the new remote controller (BRC1E62) allows the setting of both Cooling and Heating, and with the fan operation, mid-range temperatures are comfortable and operation is more energy efficient.

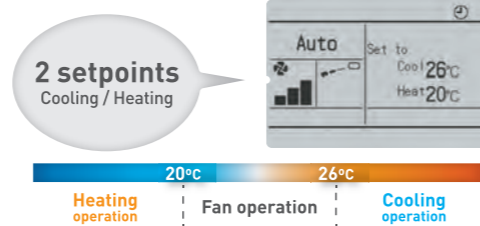

• Setpoint range set

- Saves energy by limiting the min. and max. set temperature.
- Avoids excessive cooling or heating.
- This function is convenient when the remote controller is installed at a place where any number of people may operate it.

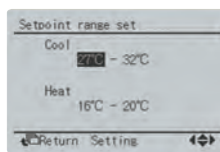

• Off timer

- Turns off the air conditioner after a preset period of time.
- Period can be preset from 30 to 180 minutes in 10-minute increments.

• Setpoint auto reset

- Even if the set temperature is changed, it returns to the preset temperature after a preset period of time.
- Period selectable from 30 min/60 min/90 min/120 min.

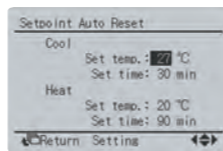

Restaurant sample

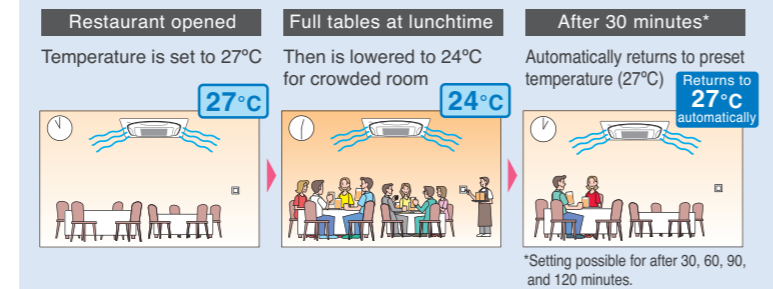

Convenience

• Setback (default: OFF)

Maintains the room temperature in a specific range during unoccupied period by temporarily starting air conditioner that was turned OFF.

Ex) Setback temperature Cooling : 35°C Recovery differential Cooling : -2°C
When the room temperature goes above 35°C, the air conditioner starts operating in Cooling automatically. When room temperature reaches 33°C, the air conditioner returns OFF.

	Setback temperature	Recovery differential
Cooling	33 — 37°C	-2 — -8°C
Heating	10 — 15°C	+2 — +8°C

• Weekly schedule

- 5 actions per day can be scheduled for each day of the week.
- The holiday function will disable schedule timer for the days that have been set as holiday.
- 3 independent schedules can be set. (e.g. summer, winter, mid-season)

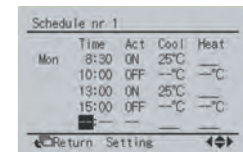

College classroom sample (a summer Monday case)

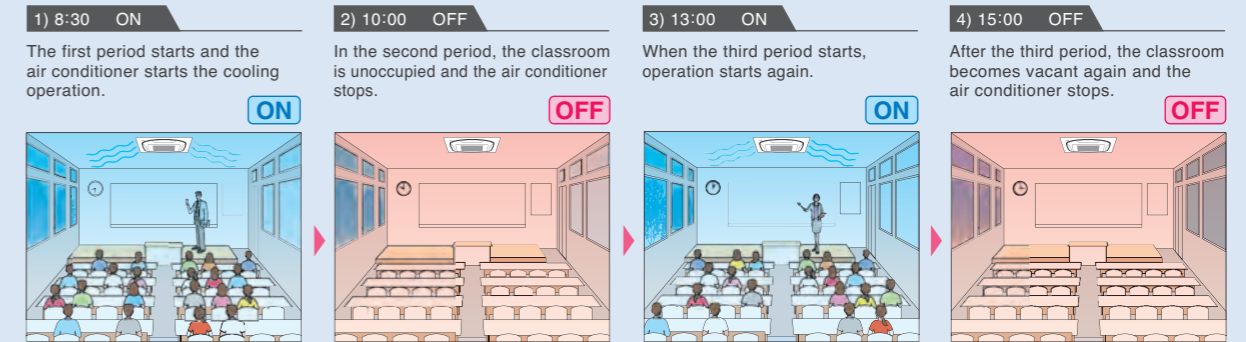

Comfort

• Individual airflow direction (*1)

Airflow direction of each of the four air outlets can be controlled individually. (Positions 0 to 4, Swing, and No individual setting are selectable.)

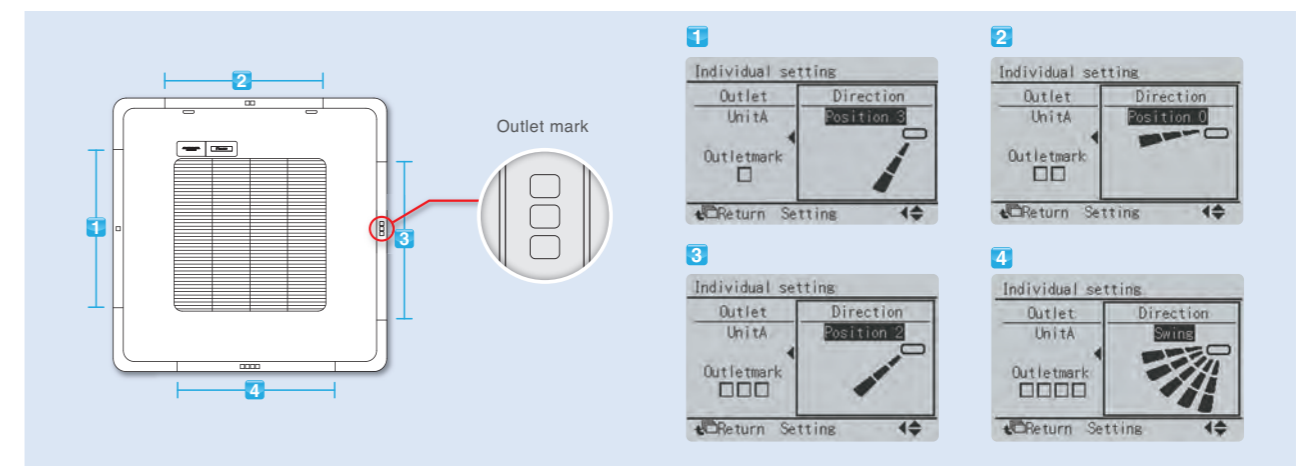

• Auto airflow rate (*2)

Airflow rate is automatically controlled in accordance with the difference between room temperature and set temperature.

*1 Only available for VRV 4-Way Flow Ceiling Suspended type FXUQ-A series and Ceiling Mounted Cassette (Round Flow with Sensing) type FXFQ-S series.

*2 Only available for VRV 4-Way Flow Ceiling Suspended type FXUQ-A series, Ceiling Mounted Cassette (Round Flow with Sensing) type FXFQ-S series and Middle Static Pressure Ceiling Mounted Duct type FXSQ-P series.

Control Systems

Individual Control Systems for VRV Indoor Units

Wired remote controller (Option)



BRC1C62

- Displays current airflow, swing, temperature, operating mode and timer settings.

* Individual airflow direction, auto airflow rate and sensing sensor control can be set only via wired remote controller BRC1E62. Cannot be set via other remote controllers.

The wired remote controller supports a wide range of control functions

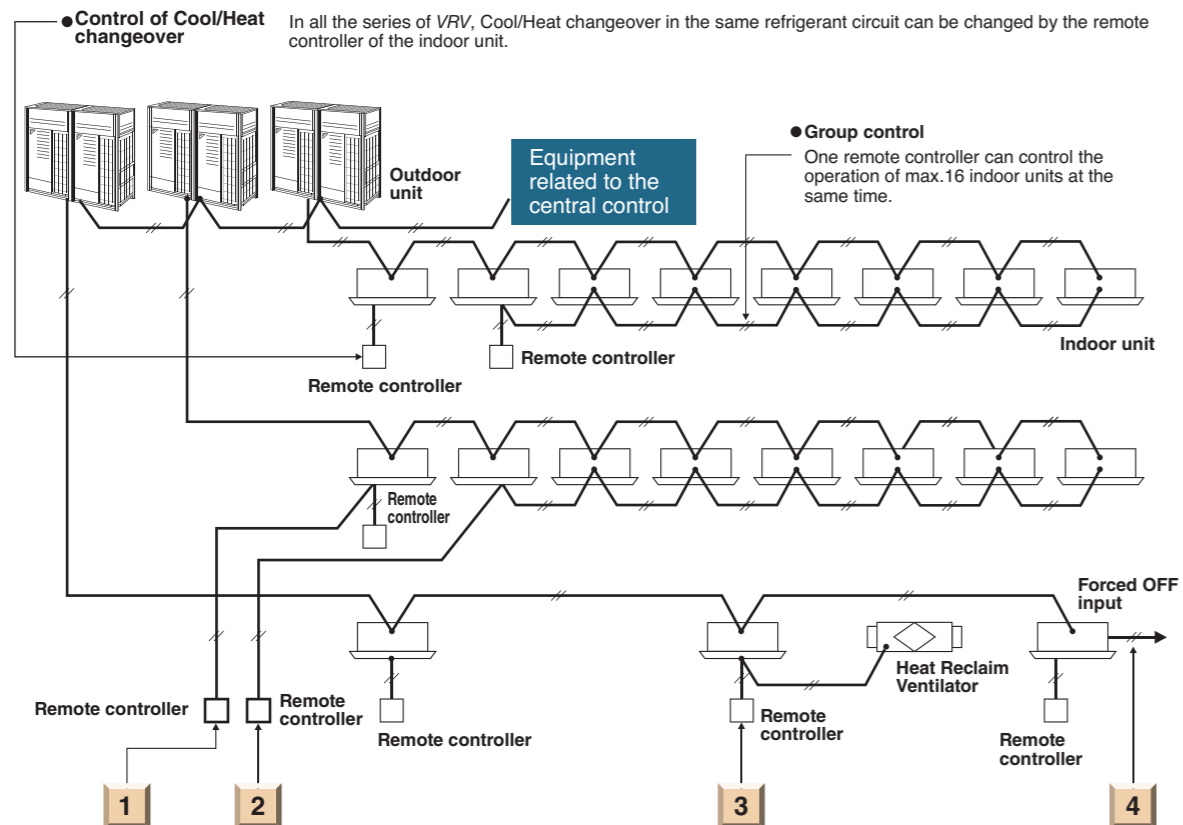

1 Control by two remote controller
The indoor unit can be connected by the two remote controller, for example one in the room and the other one in the control room, which can control the operation of indoor unit freely. (The last command has a priority.) Of course, the group control by two remote controller is also possible.

2 Remote control
The wiring of remote controller can be extended to max. 500 m and it is possible to install the remote controllers for the different indoor units in one place.

3 Control for the combined operation
The operation of Heat Reclaim Ventilator can be controlled by the remote controller of the indoor unit. Of course, the remote controller can display the time to clean the filter.

4 Expansion of system control
The system can be expanded to add several controllers, such as BMS, Forced OFF input and etc.

Wireless remote controller (Option)



Wireless remote controller

Signal receiver unit (Separate type)

- The same operation modes and settings as with wired remote controllers are possible.
- * Individual airflow direction, auto airflow rate and sensing sensor control can be set only via wired remote controller BRC1E62. Cannot be set via other remote controllers.
- A compact signal receiver unit (separate type) to be mounted into a wall or ceiling is included.
- A signal receiver unit (installed type) for a Ceiling Mounted Cassette (Round Flow, Compact Multi Flow, Double Flow) type, Ceiling Suspended type and Wall Mounted type is mounted into the indoor unit.



Signal receiver unit can be installed on the panel
ex. Ceiling Mounted Cassette (Round Flow) type



Signal receiver unit (Installed type)

* Wireless remote controller and signal receiver unit are sold as a set.
* Refer to page 47 for the name of each model.

Simplified remote controller (Option)

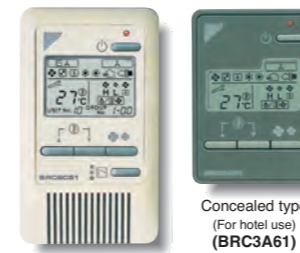

Exposed type (BRC2C51)

Concealed type (For hotel use) (BRC3A61)

- The remote controller has centralised its frequently used operation selectors and switches (on/off, operation mode, temperature setting and airflow volume), making itself suitable for use in hotel rooms or conference rooms.
- The exposed type remote controller is fitted with a thermostat sensor.



The concealed type remote controller smartly fits into a night table or console panel in a hotel room.

Wide variation of remote controllers for VRV indoor units

	FXFQ-S	FXFQ-LU	FXZQ	FXUQ	FXCQ	FXKQ	FXDQ	FXSQ	FXMQ	FXHQ	FXAQ	FXL(N)Q
Navigation remote controller (Wired remote controller) (BRC1E62)	●	●	●	●	●	●	●	●	●	●	●	●
Wired remote controller (BRC1C62)	●	●	●	●	●	●	●	●	●	●	●	●
Wireless remote controller* (Installed type signal receiver unit)	●	●	●	●	●					●	●	
Wireless remote controller* (Separate type signal receiver unit)						●	●	●	●			●
Simplified remote controller (Exposed type) (BRC2C51)							●	●	●			●
Simplified remote controller (Concealed type: for Hotel use) (BRC3A61)							●	●	●			●

*Refer to page 47 for the name of each model.

Control Systems

Integrated Building Monitoring System

The high speed transmission of DIII-NET enables more advanced control of the VRV system, providing you with enhanced comfort.

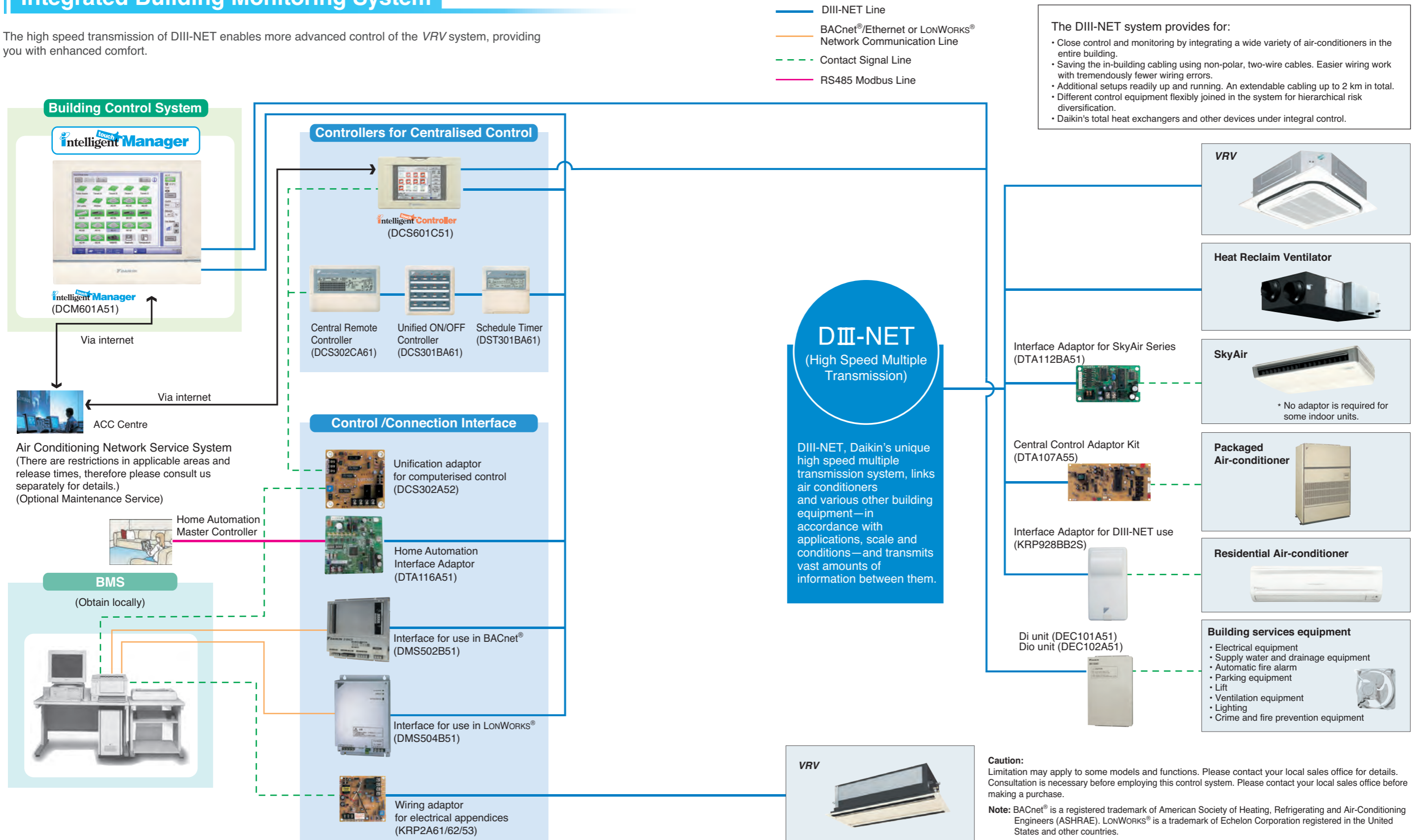

Caution: Limitation may apply to some models and functions. Please contact your local sales office for details. Consultation is necessary before employing this control system. Please contact your local sales office before making a purchase.

Note: BACnet® is a registered trademark of American Society of Heating, Refrigerating and Air-Conditioning Engineers (ASHRAE). LONWORKS® is a trademark of Echelon Corporation registered in the United States and other countries.

Control Systems

Advanced Control Systems for VRV Indoor Units

Intelligent Touch Manager

intelligent Touch Manager maximises the advantages of VRV features

intelligent Touch Manager System Overview

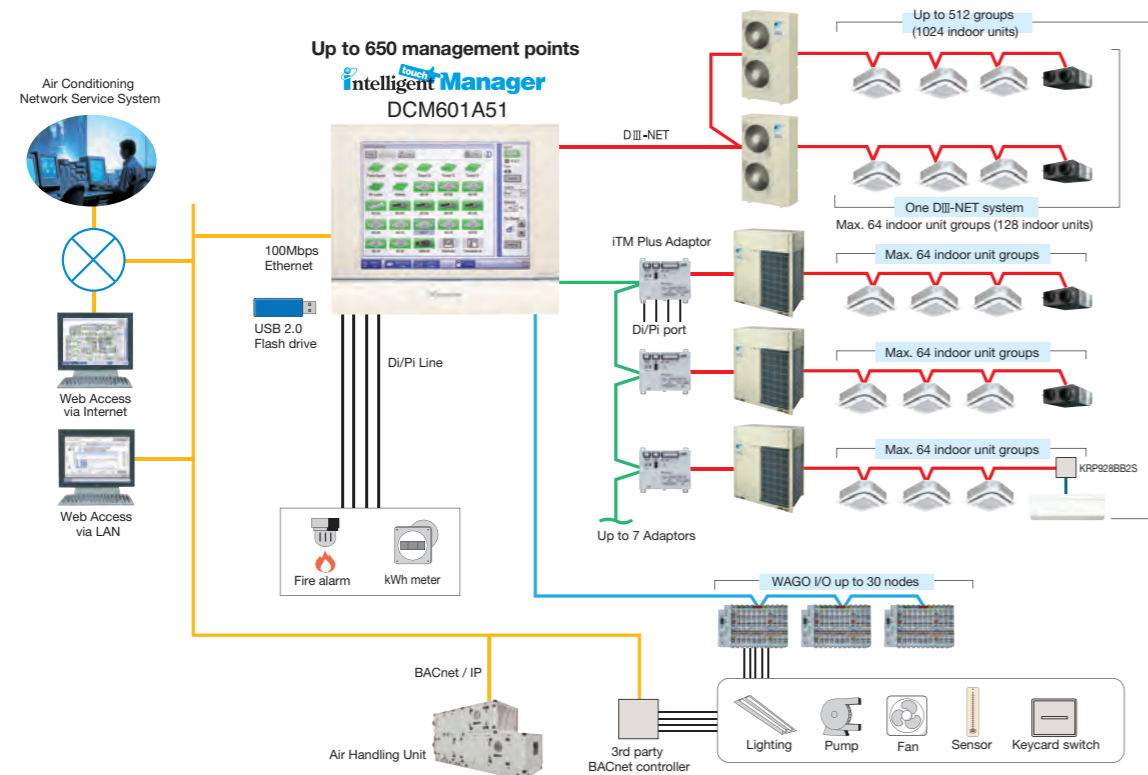

Central control

- Handy area settings simplify detailed management of VRV system.
- Display of floor plans enables a quick search of desired air conditioning units.
- Operation history shows manner of control and origin in past operations of air conditioning units.

Remote access

- Remote access with a PC allows total air conditioning management using the same type of screens as those displayed in the intelligent Touch Manager.
- Authorised users can centrally control individual air conditioning units from their own computers.

Automatic control

- VRV systems are controlled automatically throughout the year by the schedule function.
- Interlocking VRV system and other equipment enables easy automation of building facilities operation.
- Setback adjusts temperature settings even when rooms are unoccupied.

Energy management

- The Energy Navigator feature simplifies energy management by tracking energy consumption data and identifying inefficient operation.

Troubleshooting

- Contact information of maintenance contractors can be registered and displayed.
- E-mails are sent automatically to alert of malfunctions and potential trouble.
- The intelligent Touch Manager can link to the Air Conditioning Network Service System for 24-hour monitoring of operating conditions and status.

Scalability

- A single intelligent Touch Manager can manage a small building or be expanded to handle medium- to large-sized buildings.

Connectivity

- BACnet connection with a wide range of building equipment.
- WAGO Ao and Pi are newly supported and connectable WAGO modules are added.

Intelligent Touch Controller

Communication functions in the user-friendly icon-based multilingual controller simplify centralised control of the VRV system.

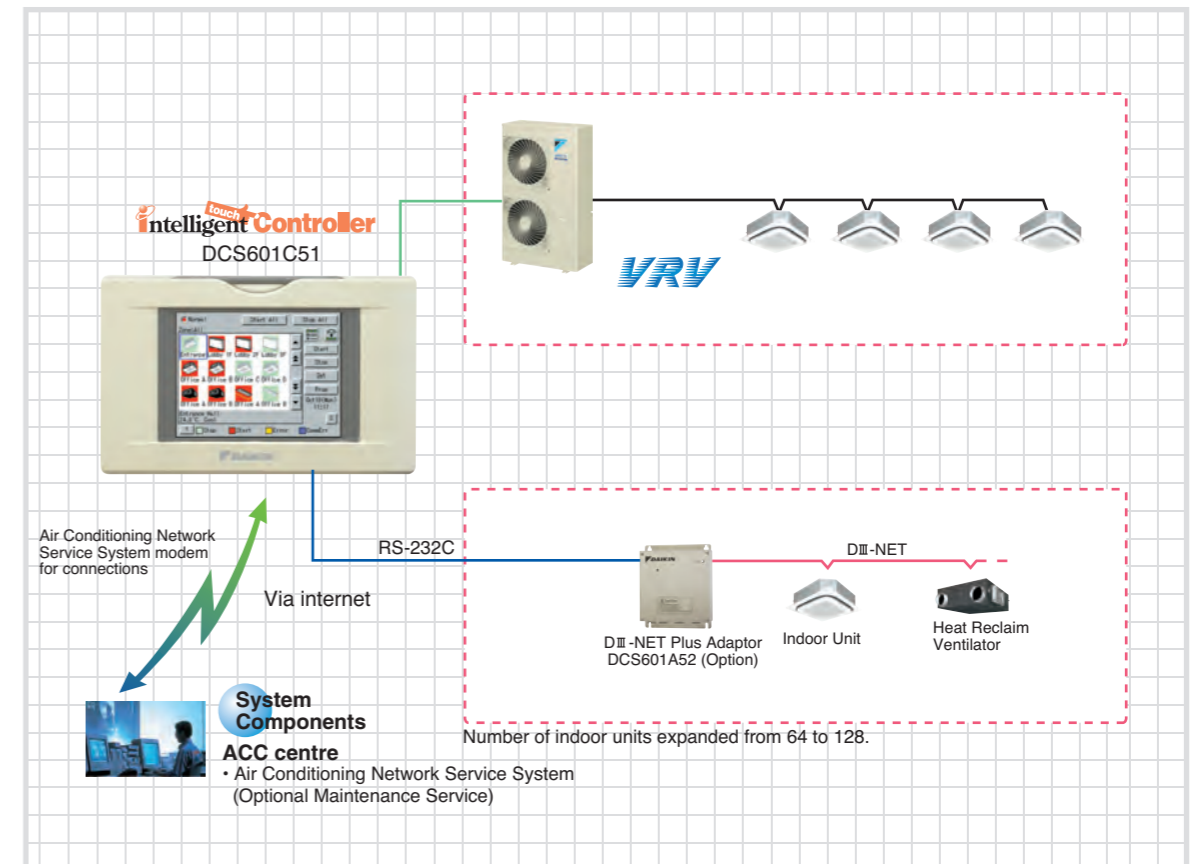

Features

- Colour LCD touch panel icon display
- Small manageable size
- Simplified engineering
- Multi language
(English, French, Italian, German, Spanish, Dutch, Portuguese, Chinese and Korean)
- Yearly schedule
- Auto heat/cool change-over
- Temperature limitation
- Enhanced history function
- Simple Interlock Function
- Built-in modem for connecting to Air Conditioning Network Service System (Option)
- Doubling of number of connectable indoor units by adding a DIII-NET Plus Adaptor (Option)



Control Systems

Advanced Control Systems for VRV Indoor Units

Home Automation Interface Adaptor

The VRV system can be operated from the home automation system.

Image to use Home Automation Interface Adaptor DTA116A51

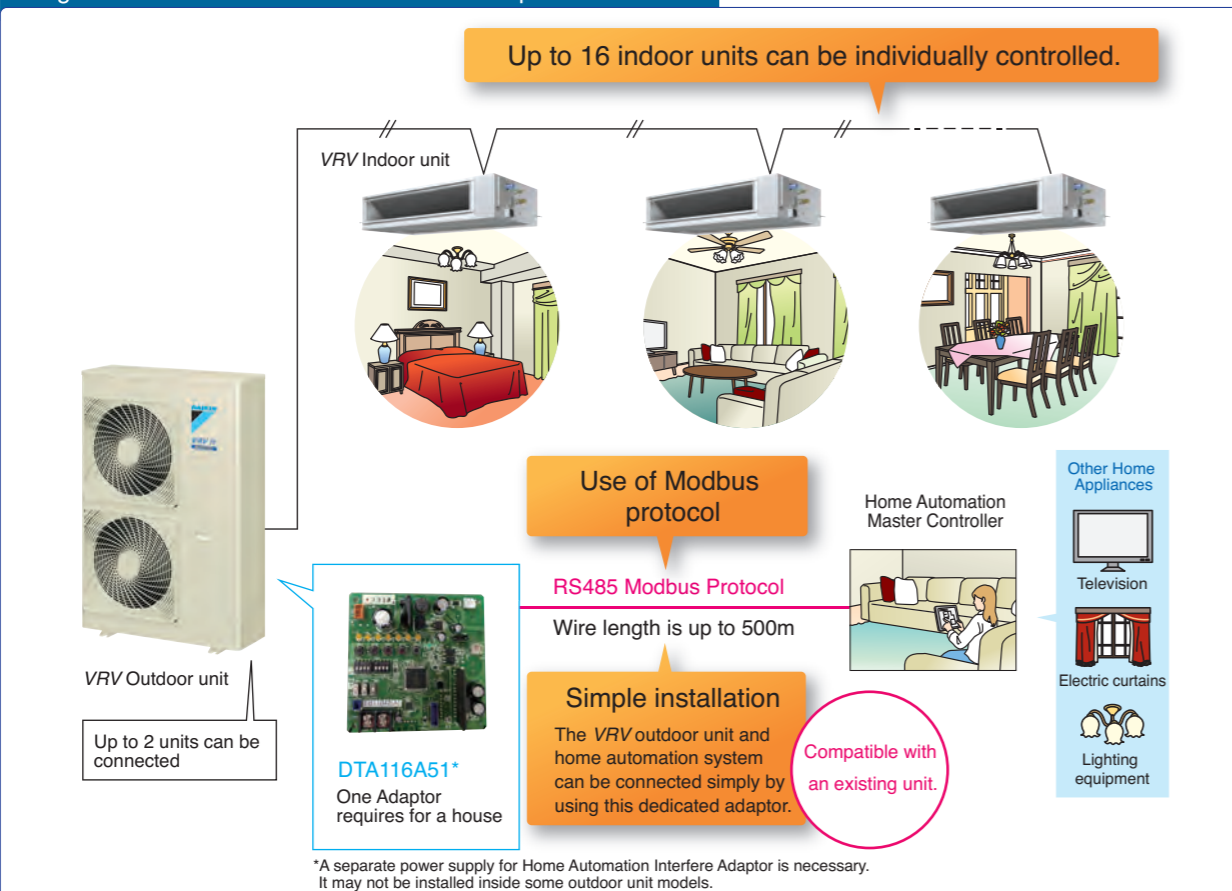

Functions

Monitor

On/Off	On/Off status of indoor units
Operation mode	Cooling, Heating, Fan, Dry, Auto (depend on indoor unit capability)
Setpoint	Setpoint of indoor units
Room temperature	Suction temperature of indoor units
Fan direction	Swing, Flap direction (depend on indoor unit capability)
Fan volume	L, M, H (depend on indoor unit capability)
Forced off status	Forced off status of indoor units
Error	Malfunction, Warning with Error code
Filter sign	Filter sign of indoor units
Communication status	Communication normal/error of indoor units

Control

On/Off	On/Off control of indoor units
Operation mode	Cooling, Heating, Fan, Dry, Auto (depend on indoor unit capability)
Setpoint	Cooling/Heating setpoint
Fan direction	Swing, Stop, Flap direction (depend on indoor unit capability)
Fan volume	L, M, H (depend on indoor unit capability)
Filter sign reset	Reset filter sign of indoor units

Retrieve system information

Connected indoor units	DIII-NET address of connected indoor units can be retrieved.
Indoor unit capabilities	Indoor unit capabilities such as operation mode, fan control, setpoint HV can be retrieved.

Interface for BACnet® and LONWORKS®

Integrated control systems that recognise the trend of open control systems

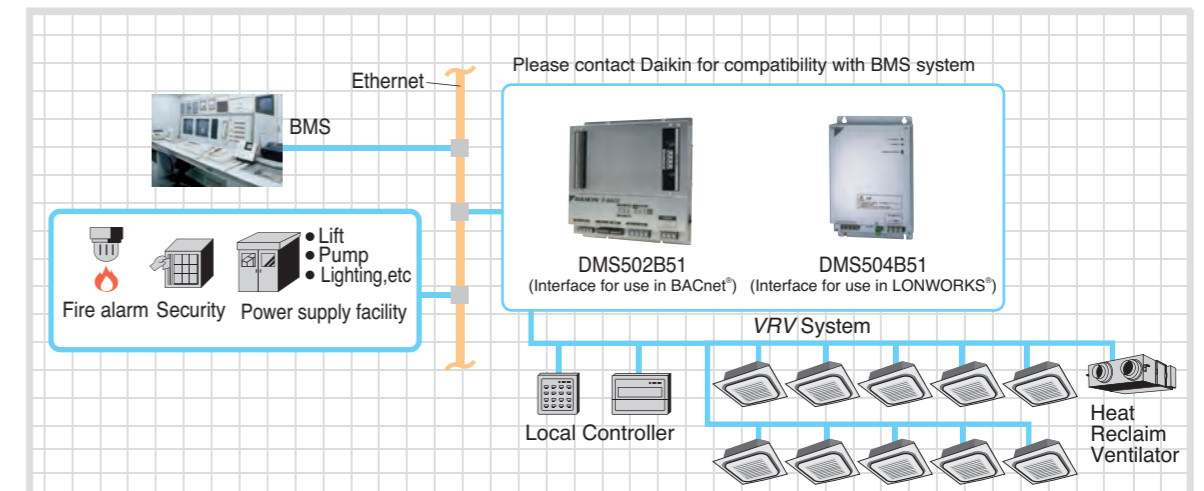

Compatibility with BMS enhanced by utilising the international communication standards, BACnet® or LONWORKS®.

DMS502B51 Interface for use in BACnet®

- Support for Heat Reclaim Ventilator VAM series
- Selectable temperature unit
- BTL Certification
- PPD data (Optional Di board is required.)
- ISO 16484-5 (Does not support IEEE 802.3 protocol for BACnet®)
- Up to 40 outdoor units and 256 indoor unit groups on one gateway (optional adaptor)

DMS504B51 Interface for use in LONWORKS®

- XIF file for confirming of specifications of the units.
- Connectable up to 10 outdoor units and 64 indoor unit groups.

Air Conditioning Network Service System

Maintenance services that boost profits and customer satisfaction

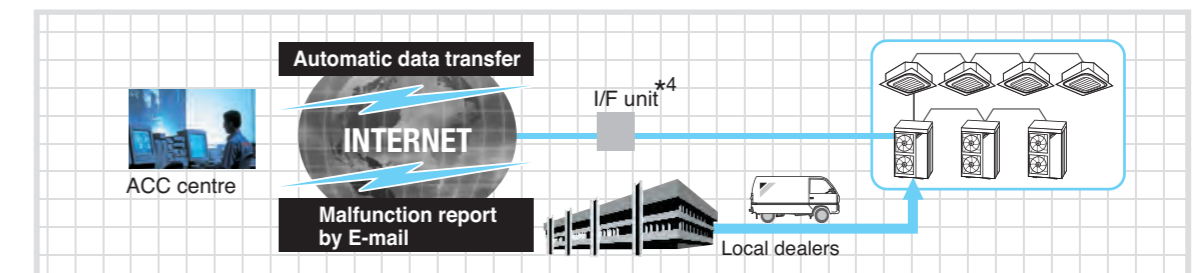

- 24 hour on-line diagnostic system
- Energy saving and extension of aircon operating life
- Maintenance management via A/C network service system reports
- Reliable service at shortest lead time

*1. Model name varies upon the system size.

*2. BACnet® is a registered trademark of American Society of Heating, Refrigerating and Air-Conditioning Engineers (ASHRAE).

*3. LonWorks® is a trademark of Echelon Corporation registered in the United States and other countries.

*4. For an I/F unit, one of the following can be selected: **Local Controller**, intelligent Touch Controller, or intelligent Touch Manager.

*5. Refer to the Options page for the name of each model.

Control Systems

Centralised Control Systems for VRV Indoor Units

- Up to 64 groups of indoor units (128 units) can be centrally controlled.
- Optional controllers for centralised control can be combined freely, and system can be designed in accordance with building scale and purpose.
- System integration with various air-conditioning peripheral equipment such as Heat Reclaim Ventilator is easy.
- Wiring can be run up to a total length of 2 km, and adapts easily to large-scale system expansion.

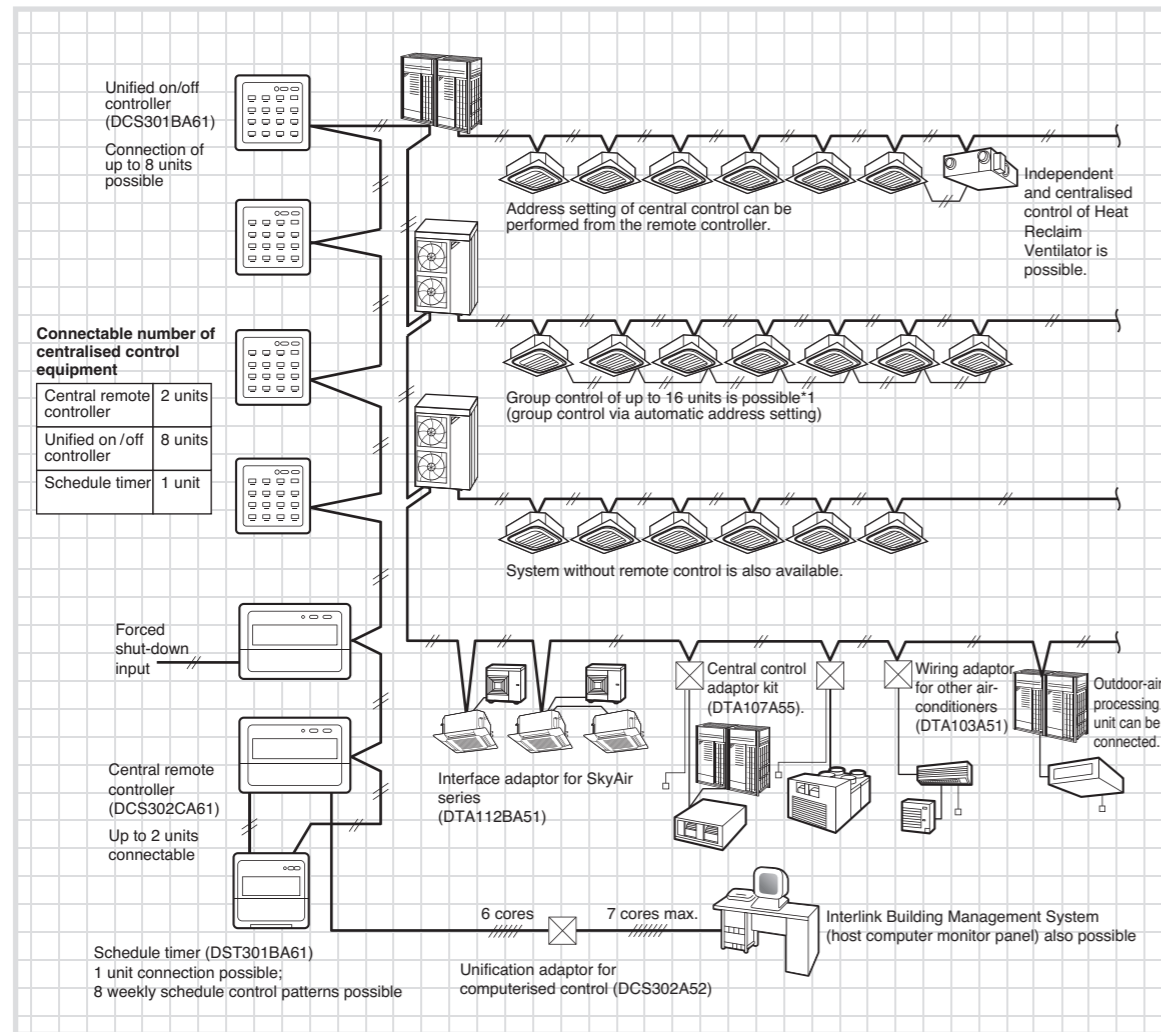

★ 1. Refer to page 42 for the total number of indoor units that can be connected to the outdoor unit.
• Certain indoor units limit the functions of some control systems.
For more details, please refer to the Engineering Data.

Residential central remote controller* (Option)



DCS303A51

Max. 16 groups of indoor units can be easily controlled with the large LCD panel.

- Max. 16 groups (128 indoor units) controllable
- Backlight and large LCD panel for easy readability
- ON/OFF, temperature settings and scheduling can be controlled individually for indoor units.
- All indoor units can be turned on or off at once with "ALL" button.
- Each group has a dedicated button for convenience.
- Outside temperature display

* For residential use only. Cannot be used with other centralised control equipment.

Central remote controller (Option)



DCS302CA61

Max. 64 groups (zones) of indoor units can be controlled individually same as LCD Remote controller.

- Max. 64 groups (128 indoor units) controllable
- Max. 128 groups (128 indoor units) are controllable by using 2 central remote controllers, which can control from 2 different places.
- Zone control
- Malfunction code display
- Max. wiring length 1,000 m (Total: 2,000 m)
- Connectable with Unified ON/OFF controller, schedule timer and BMS system
- Airflow volume and direction can be controlled individually for indoor units in each group operation.
- Ventilation volume and mode can be controlled for Heat Reclaim Ventilator.
- Up to 4 ON/OFF pairs can be set per day by connecting a schedule timer.

Unified ON/OFF controller (Option)



DCS301BA61

Max. 16 groups of indoor units can be operated simultaneously/individually.

- Max. 16 groups (128 indoor units) controllable
- 2 remote controllers can be used to control from 2 different places.
- Operating status indication (Normal operation, Alarm)
- Centralised control indication
- Max. wiring length 1,000 m (Total: 2,000 m)
- Compact size casing (Thickness: 16 mm)
- Connectable with Central Remote controller, Schedule timer and BMS system

Schedule timer (Option)



DST301BA61

Max. 128 indoor units can be operated as programmed schedule.

- Max. 128 indoor units controllable
- When used in combination with a central remote controller, a maximum of 8 weekly schedule patterns can be set, while the central controller can be used to select desired zones. Up to 2 ON/OFF pairs can be set per day.
- Max. 48 hours back up power supply
- Max. wiring length 1,000 m (Total: 2,000 m)
- Compact size casing (Thickness: 16 mm)
- Connectable with Central Remote controller, Unified ON/OFF controller and BMS system

Air Treatment Equipment Lineup

Heat Reclaim Ventilator — VAM series

The Heat Reclaim Ventilator Creates a High-Quality Environment by Interlocking with the Air Conditioner

Model Names

VAM150GJVE, VAM250GJVE, VAM350GJVE,
VAM500GJVE, VAM650GJVE, VAM800GJVE,
VAM1000GJVE, VAM1500GJVE, VAM2000GJVE

Improved Enthalpy Efficiency*¹
Higher External Static Pressure*²
Enhanced Energy Saving Functions

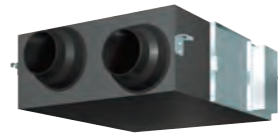

Heat Reclaim Ventilator remote controller*
BRC301B61 (Option)

* This remote controller is used in case of independent operation of Heat Reclaim Ventilator.

This VAM series provides higher enthalpy efficiency*¹, due to the greatly enhanced performance of the thin film element. Furthermore, improved external static pressure*² offers more flexibility for installation. Along with these three outstanding improvements, the nighttime free cooling operation contributes to energy conservation and more comfortable space.

*¹ For models: VAM150/250/350/650/800/1000/2000GJVE

*² For models: VAM150/350/500GJVE

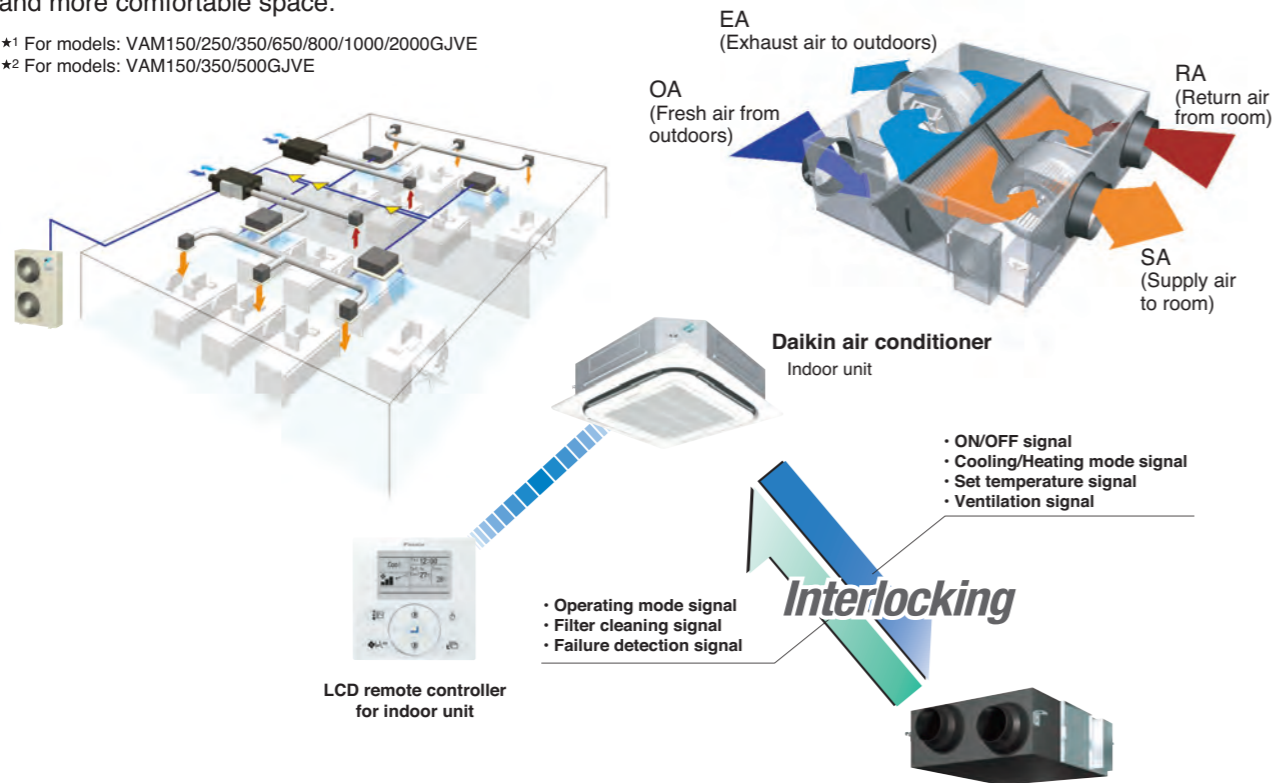

Compact Equipment

With a height of just 306 mm, the unit easily fits in limited spaces, such as above ceilings.

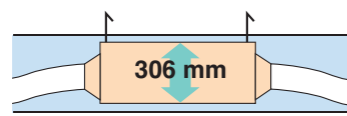

* For VAM500GJVE

Energy Conservation

Air conditioning load reduced by approximately 31%!

Cold Climate Compatible

Standard operation at temperatures down to -15°C.

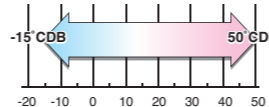

Air conditioning load reduced by approximately 31%!

Total heat exchange ventilation

This unit recovers heat energy lost through ventilation and curbs room temperature changes caused by ventilation, thereby conserving energy and reducing the load on the air conditioning system.

23%

Enthalpy efficiency drastically improved by employing thin film element! (VAM-GJ model)

Due to the thinner film...

- Decreases the moisture resistance of the partition sheets drastically.
- Realises more space for extra layers in the element, resulting in increased effective area that supply and exhaust air can be exposed to.

Thickness of the partition sheet
40 μm

Moisture absorption increased by approx. 10%!

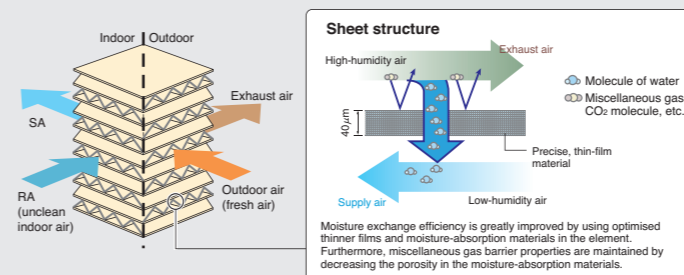

Auto-ventilation Mode Changeover Switching

6%

Automatically switches the ventilation mode (Total Heat Exchange Mode/Bypass Mode) according to the operating status of the air conditioner.

Pre-cool, Pre-heat Control

2%

Reduces air conditioning load by not running the Heat Reclaim Ventilator while air is still clean soon after the air conditioner is turned ON.

- The air conditioning load reduction values may vary according to weather and other environmental conditions at the location of the machine's installation.
- The air conditioning load reduction values are based on the following conditions:
Application: Tokyo office building
Building form: 6 floors above ground, 2 floors underground, floor area 2,100 m²
Personnel density: 0.25 person/m²
Ventilation volume: 25 m³/h
Indoor air conditioning level: summer 25°C 50% RH, intermediate seasons 24°C 50% RH, winter 22°C 40% RH
Operating time: 2745 hours (9 hours per day, approx. 25 days per month)
Calculation method: simulation based on "MICRO-HASP/1982" of the Japan Building Mechanical and Electrical Engineers Association.

Air Conditioning Load Reduced by Approximately

31%

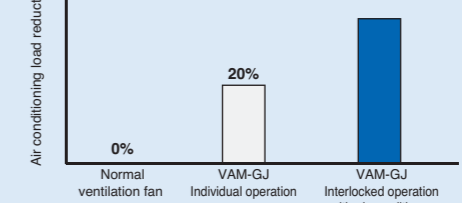

Nighttime free cooling operation*¹

Nighttime free cooling operation is an energy-conserving function that works at night when air conditioners are off. By ventilating rooms containing office equipment that raises the room temperature, nighttime free cooling operation reduces the cooling load when air conditioners are turned on in the morning. It also alleviates feelings of discomfort in the morning caused by heat accumulated during the night.

- Nighttime free cooling operation only works to cool and if connected to Building Multi or VRF systems.
- Nighttime free cooling operation is set to "off" in the factory settings, so if you wish to use it, request your dealer to turn it on.

- *¹ This function can be operated only when interlocked with air conditioners.
- *² Value is based on the following conditions:
• Cooling operation performed from April to October.
• Calculated for air conditioning sensible heat load only (latent heat load not included).

Air conditioning sensible heat load reduced by approx. 5%*²!

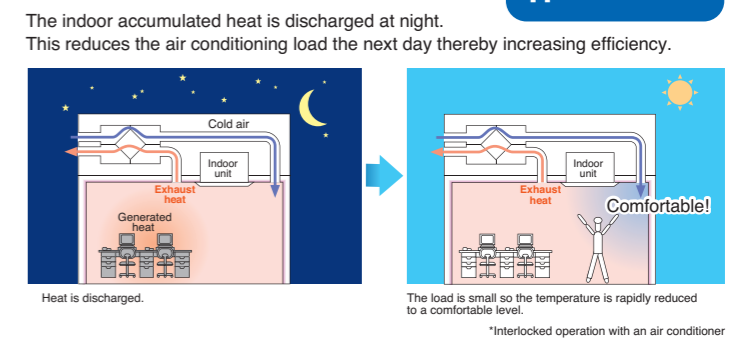

Air Treatment Equipment Lineup

Heat Reclaim Ventilator — VAM series

CO₂ Sensor Optional Kit Connection

The CO₂ sensor controls airflow so that it best matches the changes in CO₂ level. This prevents energy losses from over-ventilation while maintaining indoor air quality with optional CO₂ sensor.

Example of CO₂ sensor operation in an office room:

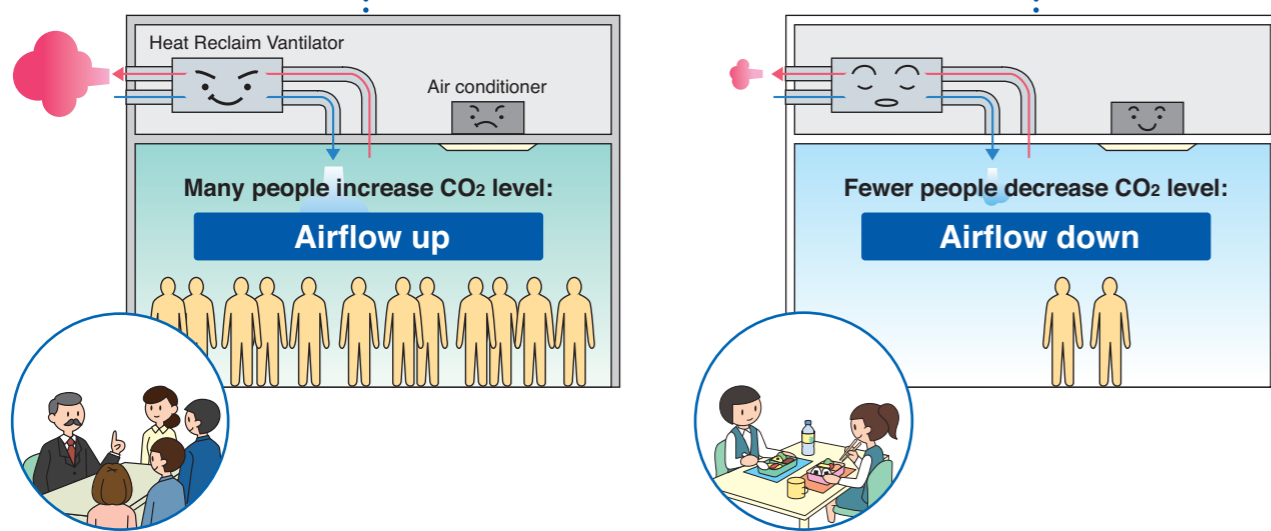
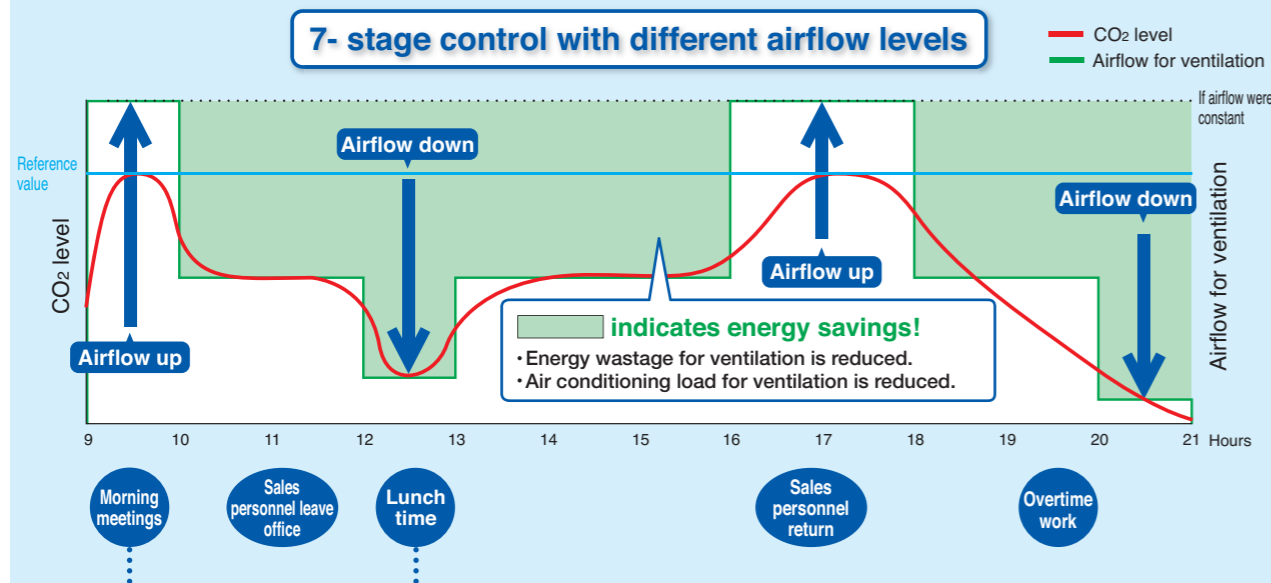

Specifications

MODEL		VAM150GJVE	VAM250GJVE	VAM350GJVE	VAM500GJVE	VAM650GJVE	VAM800GJVE	VAM1000GJVE	VAM1500GJVE	VAM2000GJVE	
Power Supply		1-phase, 220-240 V/220 V, 50 Hz/60 Hz									
Temp. Exchange Efficiency	Ultra-High	79	75	79	74	75	72	78	72	77	
	High	79	75	79	74	75	72	78	72	77	
	Low	84	79	82	80	77	74	80.5	75.5	79	
Enthalpy Exchange Efficiency	For Heating	Ultra-High	72	71	70	67	67.5	65	70	65	72
		High	72	71	70	67	67.5	65	70	65	72
		Low	76	74	77	74	71.5	67.5	72.5	67	75
	For Cooling	Ultra-High	66	63	66	55	61	61	64	61	62
		High	66	63	66	55	61	61	64	61	62
		Low	70	66	70	59	64	64	68.5	64	66
Power Consumption	Heat Exchange Mode	Ultra-High	125	137	200	248	342	599	635	1,145	1,289
		High	111	120	182	225	300	517	567	991	1,151
		Low	57	60	122	128	196	435	476	835	966
	Bypass Mode	Ultra-High	125	137	200	248	342	599	635	1,145	1,289
		High	111	120	182	225	300	517	567	991	1,151
		Low	57	60	122	128	196	435	476	835	966
Sound Level	Heat Exchange Mode	Ultra-High	27-28.5	27-29	31.5-33	33-35.5	34-36	39-40.5	39.5-41.5	39.5-41.5	41.5-43.5
		High	26-27.5	26-27.5	30-31.5	31.5-34	33-34.5	37-39.5	37.5-39.5	37.5-39.5	39-43
		Low	20.5-21.5	21-22	23-25	25-28.5	27.5-29.5	35-37.5	35-37.5	35-37.5	36-39
	Bypass Mode	Ultra-High	28.5-29.5	28.5-30.5	33-34.5	34.5-36	35-37.5	40.5-42	40.5-42.5	41-43	43-45.5
		High	27.5-28.5	27.5-29	31.5-33	33-34.5	33-35.5	38.5-40	38.5-40.5	39.5-41	40.5-45
		Low	22.5-23.5	22.5-23	24.5-26.5	25.5-28.5	27.5-30.5	36-38.5	36-38.5	36.5-38	37.5-39.5
Casing		Galvanised steel plate									
Insulation Material		Self-extinguishable polyurethane foam									
Dimensions (HXWXD)	mm	278×810×551	306×879×800			338×973×832	387×1,111×832	387×1,111×1,214	785×1,619×832	785×1,619×1,214	
Machine Weigh	kg	24	32			45	55	67	129	157	
Heat Exchange System		Air to air cross flow total heat (Sensible heat + latent heat) exchange									
Heat Exchange Element Material		Specially processed nonflammable paper									
Air Filter		Multidirectional fibrous fleeces									
Fan	Type	Sirocco fan									
	Airflow Rate	Ultra-High	150	250	350	500	650	800	1,000	1,500	2,000
		High	150	250	350	500	650	800	1,000	1,500	2,000
		Low	100	155	230	320	500	700	860	1,320	1,720
	External Static Pressure	Ultra-High	120	70	169	105	85	133	168	112	116
		High	106	54	141	66	53	92	110	73	58
Low		56	24	67	32	35	72	85	56	45	
Motor Output	kW	0.030×2		0.090×2		0.140×2		0.280×2		0.280×4	
Connection Duct Diameter	mm	φ100	φ150		φ200		φ250		φ350		
Unit Ambient Condition		-15°C~50°CDB, 80%RH or less									

- Notes:
- Sound level is measured at 1.5 m below the centre of the body.
 - Airflow rate can be changed over to Low mode or High mode.
 - Sound level is measured in an anechoic chamber.
 - Sound level generally becomes greater than this value depending on the operating conditions, reflected sound, and peripheral noise.
 - The sound level at the air discharge port is about 8 dB(A) higher than the unit's sound level.
 - The specifications, designs and information given here are subject to change without notice.
 - Temperature Exchange Efficiency is the mean value between cooling and heating.
 - Efficiency is measured under the following conditions: Ratio of rated external static pressure has been maintained as follows; outdoor side to indoor side = 7 to 1.
 - In conformance with JIS standards (JIS B 8628), operating sound level is based on the value when one unit is operated, with the value converted for an anechoic chamber. This is transmission sound from the main unit, and does not include sound from the discharge grille. Thus it is normal for the sound to be louder than the indicated value when the unit is actually installed.
 - Sound level from the discharge port causes the value to be approximately 8 dB(A) (models with the airflow rate of less than 150 to 500 m³/h) to approximately 11 dB(A) (models with the airflow rate of 650 m³/h or more) greater than the indicated value. Furthermore, fan rotation and noise from the discharge grille may increase depending on the on-site duct resistance conditions. Please consider noise countermeasures when installing the unit.
 - With large models in particular (1500 and 2000 m³/h models), if the supply air (SA) grille is installed near the main unit, the noise of the main unit may be heard from the discharge grille via the duct, and this will result in a marked increase in noise. In such cases, if peripheral effects are included (such as reverberation of the floor and walls, combination with other equipment, and background noise), sound level may be as much as 15 dB(A) higher than the indicated value. When installing a large model, please provide as much separation as possible between the main unit and the discharge grille. If the equipment and discharge grille are near each other, please consider countermeasures such as the following:
 - Use a sound-muffling box, flexible duct and sound-muffling air supply/discharge grilles
 - Decentralised installation of discharge grilles
 - When installing in a location with particularly low background noise such as a classroom, please consider the following measures to avoid transmission sound from the main unit:
 - Use of ceiling materials with high sound insulating properties (high transmission loss)
 - Methods of blocking sound transmission, for example, by adding sound insulating materials around the bottom of the sound source.
 Alternatively, consider supplementary methods such as installing the equipment in a different location (corridor, etc.)

Air Treatment Equipment Lineup

Options

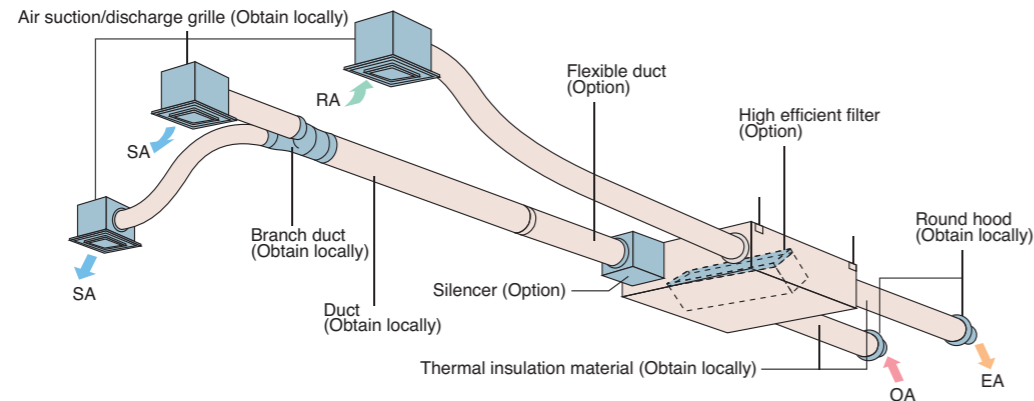

Option List

Item	Type	VAM150 · 250 · 350 · 500 · 650 · 800 · 1000 · 1500 · 2000GJVE																				
Heat Reclaim Ventilator remote controller		BRC301B61																				
Centralised controlling device	Residential central remote controller	DCS303A51 *1																				
	Central remote controller	DCS302CA61																				
	Unified ON/OFF controller	DCS301BA61																				
	Schedule timer	DST301BA61																				
Controlling device	Wiring adaptor for electrical appendices	KRP2A61																				
	For humidifier	KRP50-2																				
	Installation box for adaptor PCB	KRP50-2A90 (Mounted electric component assy of Heat Reclaim Ventilator)																				
	For heater control kit	BRP4A50																				
	PC Board Adaptor	For wiring	Type (indoor unit of VRV)	FXFQ-S	FXFQ-LU	FXZQ-M	FXUQ-A	FXCQ-M	FXKQ-MA	FXDQ-PB	FXDQ-NB	FXSQ-P	FXMQ-P	FXMQ-MA	FXHQ-MA	FXAQ-P	FXLQ-MA	FXNQ-MA				
Installation box for adaptor PCB**			KRP1C63*	KRP1BA57*	KRP1C67	KRP1B61*	KRP1B61	KRP1B56*	KRP1C64*	KRP1C64*	KRP1B61	KRP1BA54	—	KRP1B61	Notes 2, 3 KRP1H98	Notes 4, 6 KRP1BA101	Notes 2, 3 KRP1B96	Notes 4, 6 KRP1BA101	Notes 2, 3 KRP4A98	Notes 2, 3 KRP4A96	Note 3 KRP1CA93	Notes 2, 3 KRP4AA93

Notes: 1. Installation box ** is necessary for each adaptor marked *.
 2. Up to 2 adaptors can be fixed for each installation box.
 3. Only one installation box can be installed for each indoor unit.
 4. Up to 2 installation boxes can be installed for each indoor unit.
 5. Installation box ** is necessary for second adaptor.
 6. Installation box ** is necessary for each adaptor.
 7. *1 For residential use only. When connected with a Heat Reclaim Ventilator (VAM), you can only switch the power ON/OFF. Cannot be used with other centralised control equipment.

Item	Type	VAM150GJVE	VAM250GJVE	VAM350GJVE	VAM500GJVE	VAM650GJVE	VAM800GJVE	VAM1000GJVE	VAM1500GJVE	VAM2000GJVE
Additional function	Silencer	—			KDDM24B50	KDDM24B100			KDDM24B100X2	
	Nominal pipe diameter	—			φ 200	φ 250			φ 250	
	High efficiency filter	KAF242H25M		KAF242H50M		KAF242H65M	KAF242H80M	KAF242H100M	KAF242H80MX2	KAF242H100MX2
Air filter for replacement	KAF241G25M		KAF241G50M		KAF241G65M	KAF241G80M	KAF241G100M	KAF241G80MX2	KAF241G100MX2	
Flexible duct (1 m)	K-FDS101D	K-FDS151D	K-FDS201D			K-FDS251D				
Flexible duct (2 m)	K-FDS102D	K-FDS152D	K-FDS202D			K-FDS252D				
Duct adaptor	Nominal pipe diameter	—			—			YDFA25A1		
	mm	—			—			φ 250		
CO ₂ sensor		—			BRYMA65	BRYMA100			BRYMA65	BRYMA100

PC board adaptor for heater control kit (BRP4A50)

When the installation of an electric heater is required in a cold region, this adaptor with an internal timer function eliminates the complicated timer connecting work that was necessary with conventional heaters.

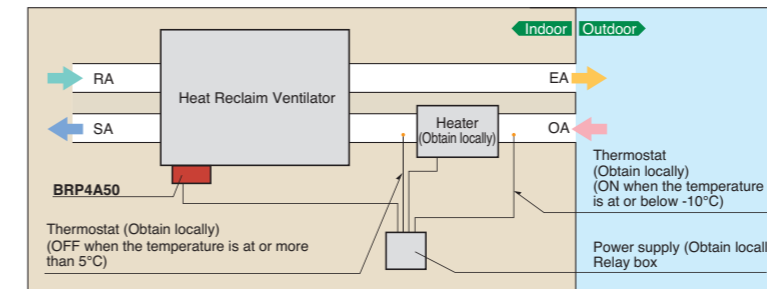

Notes when installing

- Examine fully an installation place and specification for using the electric heater based on the standard and regulation of each country.
- Supply the electric heater and safety production devices such as a relay and a thermostat, etc of which qualities satisfy the standard and regulation of each country at site.
- Use a non-inflammable connecting duct to the electric heater. Be sure to allow 2 m or more between the electric heater and the Heat Reclaim Ventilator for safety.
- For the Heat Reclaim Ventilator, use a different power supply from that of the electric heater and install a circuit breaker for each.